

The Un-Official

RCMC & RailSounds LITE Guide

Covers basic wiring information about the RCMC and LITE boards.

Info & Discretion

- The wiring diagrams were created from inspecting 15+ current products of my own, that were produced at different time periods from Lionel® ranging from diesel to steam locomotives that have this type of electronic package.
- I spent my own time creating these documents to help myself and the repair/service station community.
- If your engine is equipped with Lit number boards, they are powered off track power not the RCMC board.
- There is no documentation in this detail currently about this generation of LEGACY® Electronics.
- As of 2016 there are 7 revisions of the RCMC. Current one has Thermal resistors “Thermistor” inside the smoke units to measure the temperature. An extra pin was added to each smoke unit harness for this.
- Electro-coupler plugs on the board have 1 extra pin now too. It is unknown to me why they were added.
- The RailSounds (RS) switch is almost not used anymore on any models.
- LED’s are Polarity Sensitive. If installed backwards they will not work.

Info & Discretion

- Covers basic pin out and wiring information about the RCMC and LITE boards.
- This does not cover technical troubleshooting. (My advice is too send it back)
- This has not been looked at by Lionel. It is unclear how accurate the wiring diagrams are. I warn you to always trace your wires. Some wiring will vary from model to model.
- Colors of wires will vary model to model. Colors shown are not 100% accurate.
- Lighting outputs will vary from model to model.
- **NOT ALL “common” outputs on the RCMC is common to the chassis ground.** You will damage the board if grounded to chassis. Please use a Test meter to confirm your pin out.
- I’m still not 100% Clear on all the abbreviations for the pin outs. Educated guess mostly.
- Plug “J2” on the RCMC is not typically used. I’ve seen it used on the Legacy controlled dummy units with smoke units and electro-couplers. A Hall effect sensor is installed to trigger the cab lights offs and kick the RPM up on the smoke units fan motor when it starts to move.
- It is also used in the VL Big Boy for the smoke stack to turn off one of the stack fans when the deflector is placed on the top. It also is used to connect external PCBs such as the (SFC) and Coil Drive board for the swinging bell. On the Centipedes its used to run the overhead fans. I’ve only seen it used mainly in the Vision Line engines. A more detailed diagram of this will be made in future updates. (If I can get my hands on a VL Big Boy)

RCMC

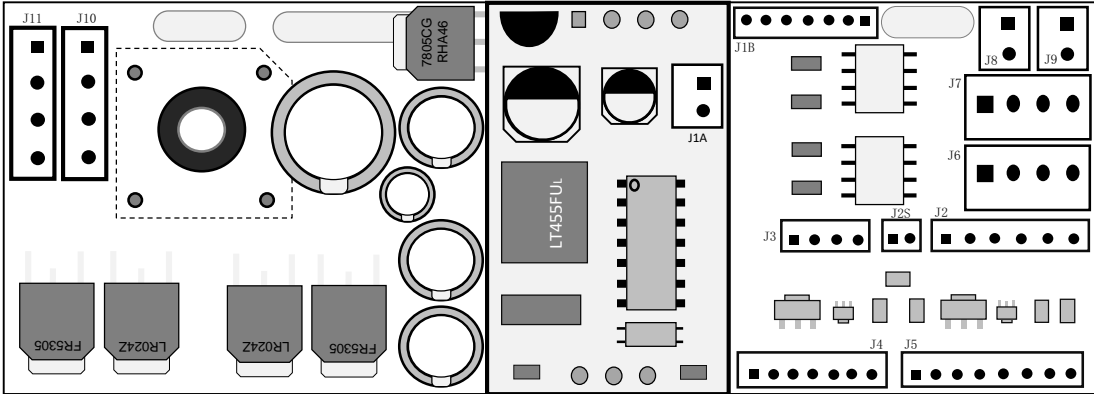

RCMC PLUG BREAK DOWN

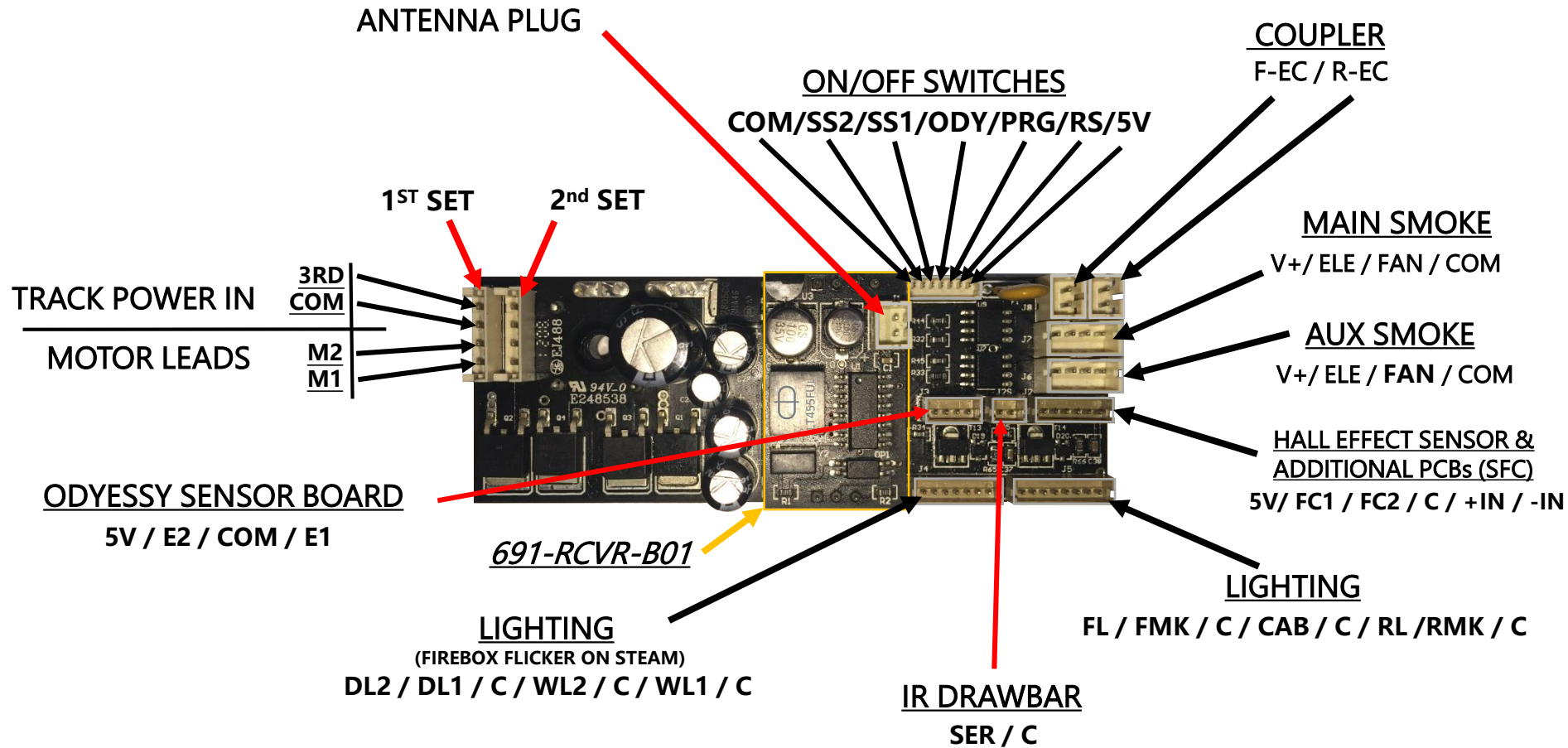

RCMC PIN BREAK DOWN	
ABRV	TERM
3RD	HOT (CENTER RAIL PICK UP)
COM	COMMON GROUND
M1	MOTOR LEAD 1
M2	MOTOR LEAD 2
SS1	SMOKE SWITCH 1
SS2	SMOKE SWITCH 2
ODY	ODYSSEY SWITCH
PRG	PROGRAM/RUN SWITCH
RS	?
5V	5 VOLTS +
F-EC	FRONT ELECTRO COUPLER
R-EC	REAR ELECTRO COUPLER
V+	POSITIVE OUTPUT VOLTAGE
ELE	HEATING ELEMENT
FAN	SMOKE FAN MOTOR
FC1	?
FC2	?
FL	FRONT LIGHT
FMK	FRONT MARKER LIGHTS
RMK	REAR MARKER LIGHTS
CAB	CAB LIGHT
RL	REAR LIGHT
SER	SERIAL DATA LINE
DL1	DITCH LIGHT 1
DL2	DITCH LIGHT 2
WL1	WORK/GROUND LIGHT 1
WL2	WORK/GROUND LIGHT 2
C	COMMON GROUND
+IN	?
-IN	?
E1	?
E2	?

NOTE:

Each RCMC board is programmed for the specific product it came from. Make sure when ordering a new RCMC board, it has the correct part number for the item you are repairing.

Diagram Perfected By:
Bruk Bannister with help from **Lionel LLC.**

Revised January, 2019

NOTES:

- (C)= COMMON GROUND TO BOARD NOT CHASSIS GROUND
- THIS VERSION HAS NO THERMISITORS IN THE SMOKE UNITS

RCMC Wiring Diagram

(Steam)

NOTE:

Each RCMC board is programmed for the specific product it came from. Make sure when ordering a new RCMC board, it has the correct part number for the item you are repairing.

(Hot)
Center Rail Pick Up

TRACK
CHASSIS
GROUND

(TYPICALLY) GRAY

A FEW STEAM MODELS WILL HAVE TWO MOTORS. BUT TYPICALLY ONE IS USED. CONSULT DIESEL DIAGRAM FOR WIRING TWO MOTORS.

MOTOR LEAD 2

MOTOR LEAD 1

MOTOR

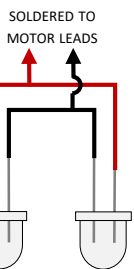

ASH PAN GLOW LIGHTS
(IF EQUIPPED) THERE IS A SET ON THE LEFT AND RIGHT SIDE OF MOTOR.

Motor Sensor Board

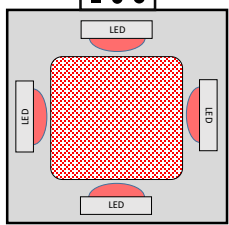

Flickering Fire Box
PCB

Ground Light 1

Ground Light 2

Front Headlight

Front Marker Light

Front Marker Light

Cab Light

Rear Headlight

Rear Marker Light

Rear Marker Light

(IF EQUIPPED)

WIRE COLOR WILL VARY

Diagram 1

NOTE:

LED's are Polarity Sensitive. If installed backwards they will not work.

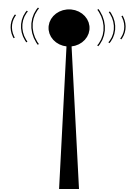

SMK AUX SMK MAIN ODY ON/OFF PRG/RUN

IR Drawbar Transmitter

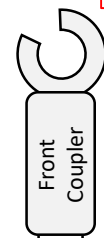

(IF EQUIPPED)

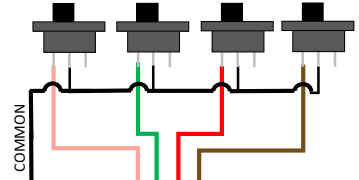
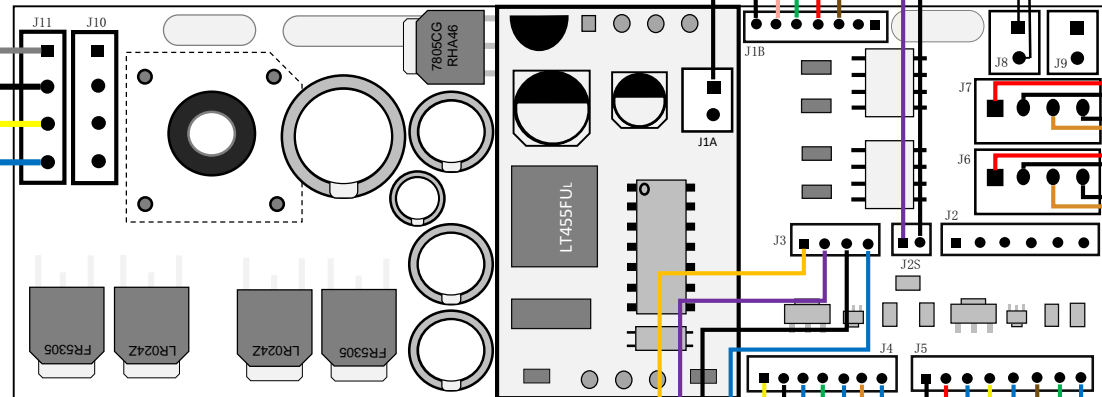

SERIAL
COMMON

MAIN SMK MOTOR

HEATING ELEMENT

AUX SMK MOTOR

HEATING ELEMENT

IF EQUIPPED

5v E2 COM E1 COMMON COMMON

"Special" Lighting
Output location may vary per model for certain lighting features such as:

- MARS Lights
- Strobe Lights
- Emergency Lights
- Warning Lights
- Flashing Beacons
- Ground Lights
- Work Lights
- Number Boards
- Lit Gauges

IT IS RECOMMEND TO TRACE THE WIRES FROM THE LED TO THE PIN OUTS ON THE BOARD

WIRE COLOR WILL VARY

RCMC Wiring Diagram

(Steam)

WIRE COLOR WILL VARY

Diagram 2

NOTE:
The "PCB female Plug end" is used for a visual reference only, the wire location on PCB might vary. Always test pin outs with a meter to avoid damage to both the RCMC board and RS-LITE board.

NOTE:
Each RCMC board is programmed for the specific product it came from. Make sure when ordering a new RCMC board, it has the correct part number for the item you are repairing.

(Hot)
Center Rail Pick Up

TRACK
CHASSIS
GROUND

(TYPICALLY) GRAY

A FEW STEAM MODELS WILL HAVE TWO MOTORS. BUT TYPICALLY ONE IS USED. CONSULT DIESEL DIAGRAM FOR WIRING TWO MOTORS.

MOTOR LEAD 2

MOTOR LEAD 1

MOTOR

SOLDERED TO
MOTOR LEADS

ASH PAN GLOW LIGHTS
(IF EQUIPPED) THERE IS A SET ON THE LEFT AND RIGHT SIDE OF MOTOR.

Motor Sensor Board

Flickering Fire Box
PCB

Ground Light 1

Ground Light 2

Front Headlight

Front Marker Light

Front Marker Light

Cab Light

Rear Headlight

Rear Marker Light

Rear Marker Light

(IF EQUIPPED)

WIRE COLOR WILL VARY

"Special" Lighting
Output location may vary per model for certain lighting features such as:

- MARS Lights
- Strobe Lights
- Emergency Lights
- Warning Lights
- Flashing Beacons
- Ground Lights
- Work Lights
- Number Boards
- Lit Gauges

IT IS RECOMMEND TO TRACE THE WIRES FROM THE LED TO THE PIN OUTS ON THE BOARD

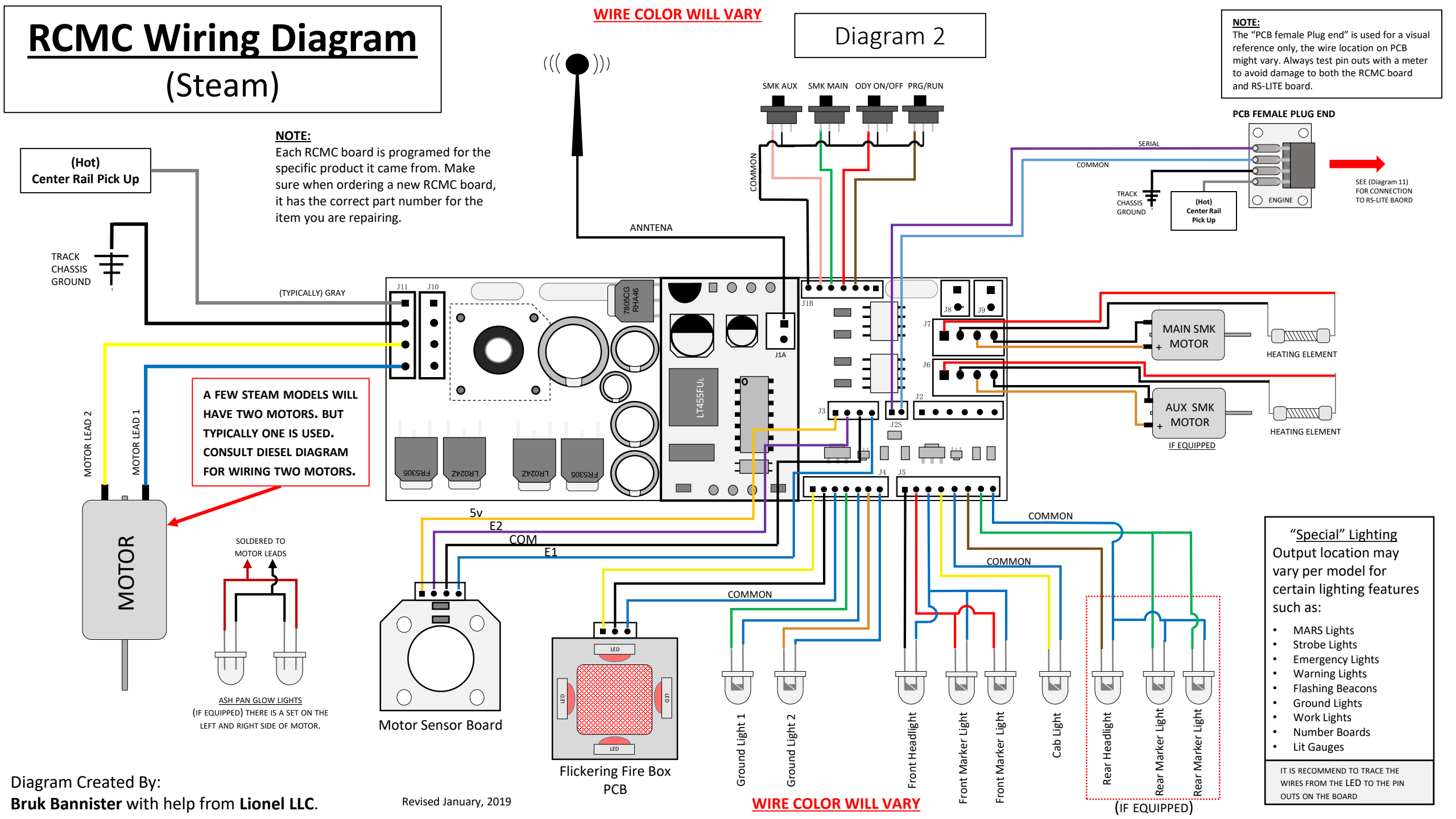

RCMC Wiring Diagram

(Diesel/Electric)

WIRE COLOR WILL VARY

Diagram 3

NOTE:
LED's are Polarity Sensitive.
If installed backwards they
will not work.

NOTE:
Each RCMC board is programmed for the
specific product it came from. Make
sure when ordering a new RCMC board,
it has the correct part number for the
item you are repairing.

(Hot)
Center Rail Pick Up

TRACK
CHASSIS
GROUND

(TYPICALLY) GRAY

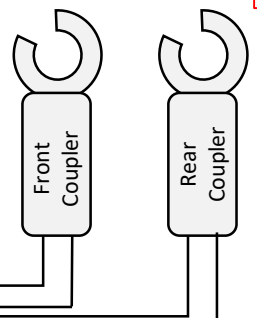
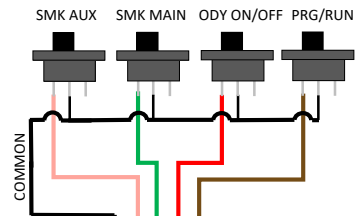
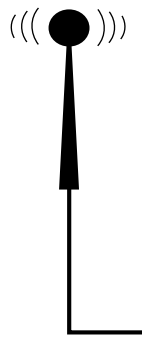

MAIN SMK
MOTOR

AUX SMK
MOTOR
IF EQUIPPED

CONNECTS TO
SOUND BOARD.
SEE DIAGRAM 3b

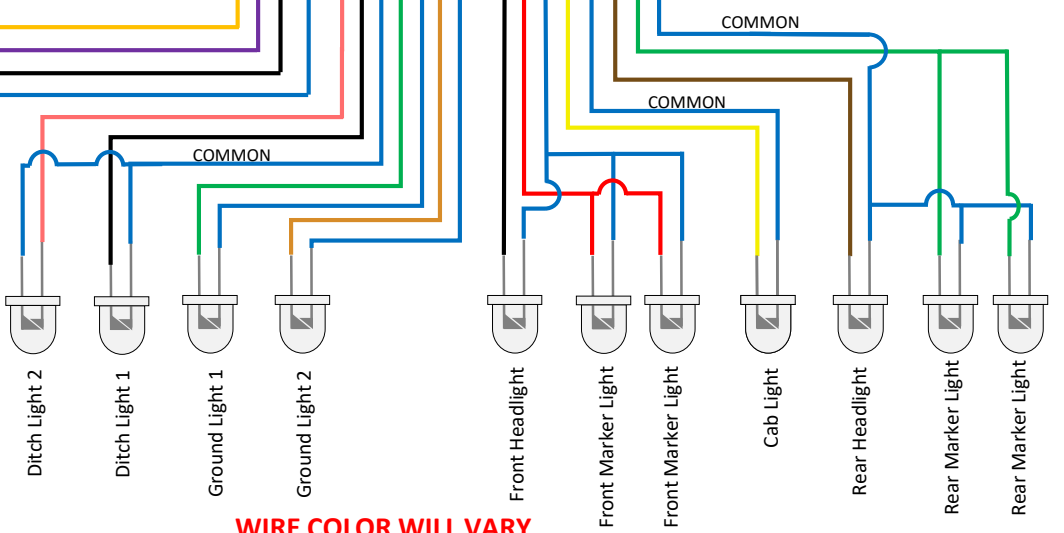
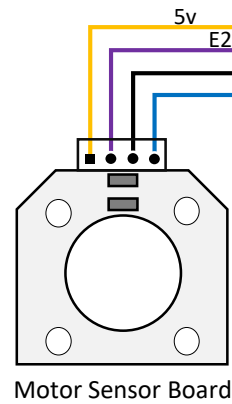
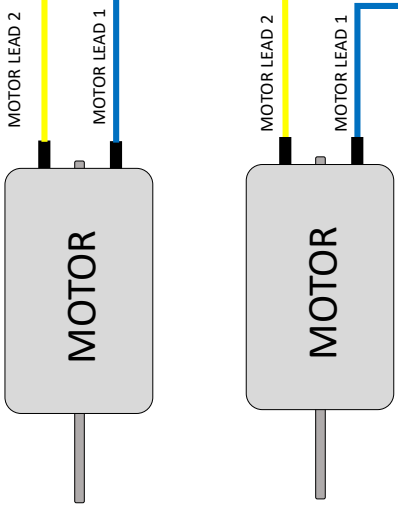
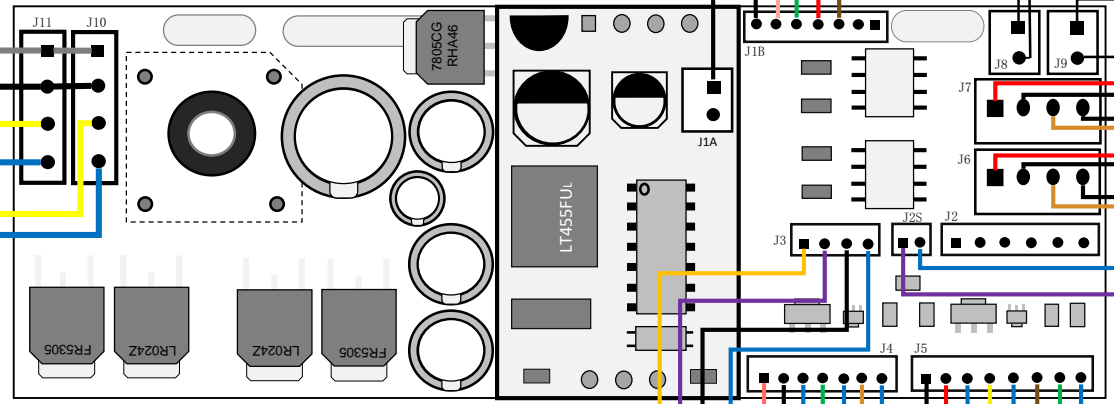

"Special" Lighting
Output location may
vary per model for
certain lighting features
such as:

- MARS Lights
- Strobe Lights
- Emergency Lights
- Warning Lights
- Flashing Beacons
- Ground Lights
- Work Lights
- Number Boards
- Lit Gauges

IT IS RECOMMEND TO TRACE THE
WIRES FROM THE LED TO THE PIN
OUTS ON THE BOARD

WIRE COLOR WILL VARY

RCMC Wiring Diagram

(Non-Powered Unit)

WIRE COLOR WILL VARY

Diagram 4

NOTE:
Each RCMC board is programmed for the specific product it came from. Make sure when ordering a new RCMC board, it has the correct part number for the item you are repairing.

(Hot)
Center Rail Pick Up

TRACK
CHASSIS
GROUND

(TYPICALLY) GRAY

NOTE:
LED's are Polarity Sensitive. If installed backwards they will not work.

"Special" Lighting
Output location may vary per model for certain lighting features such as:

- MARS Lights
- Strobe Lights
- Emergency Lights
- Warning Lights
- Flashing Beacons
- Ground Lights
- Work Lights
- Number Boards
- Lit Gauges

IT IS RECOMMEND TO TRACE THE WIRES FROM THE LED TO THE PIN OUTS ON THE BOARD

NOTE:
Not all lighting features are used in non-powered unit.

NOTE:
Hall Effect Sensors come in different shapes, sizes and part numbers. A generic shape is used for visual aid. Check the parts site for your specific item.

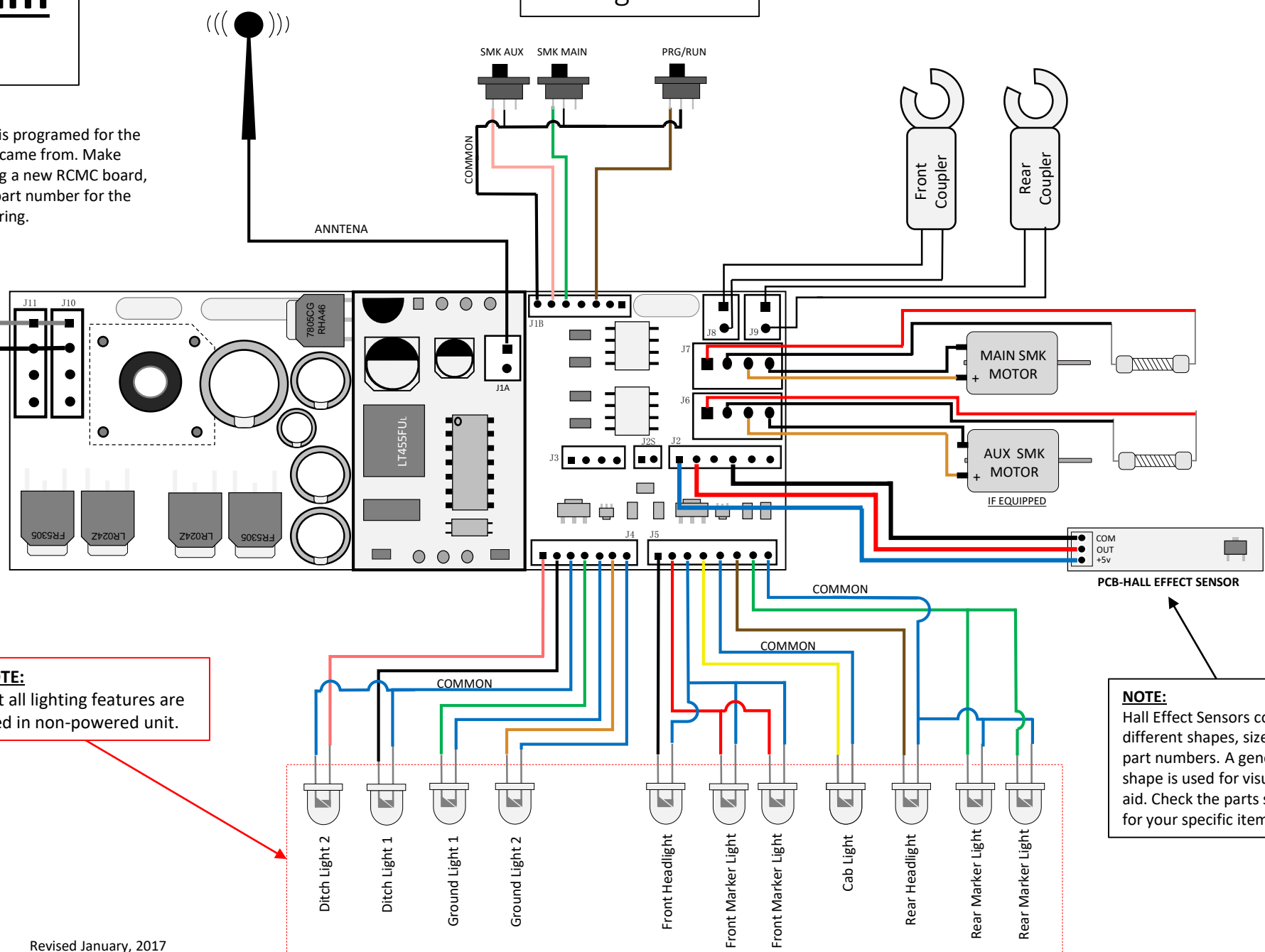

RCMC
WITH THERMISTORS

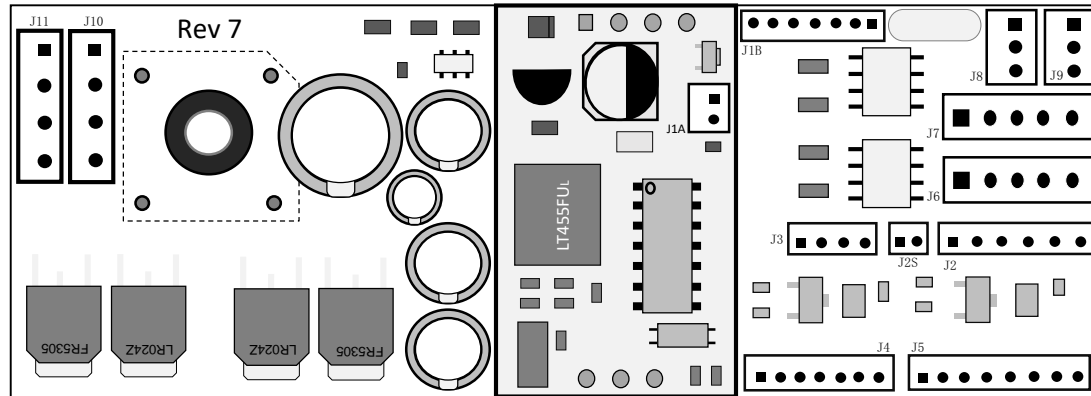

RCMC PLUG BREAK DOWN

(with Thermistors)

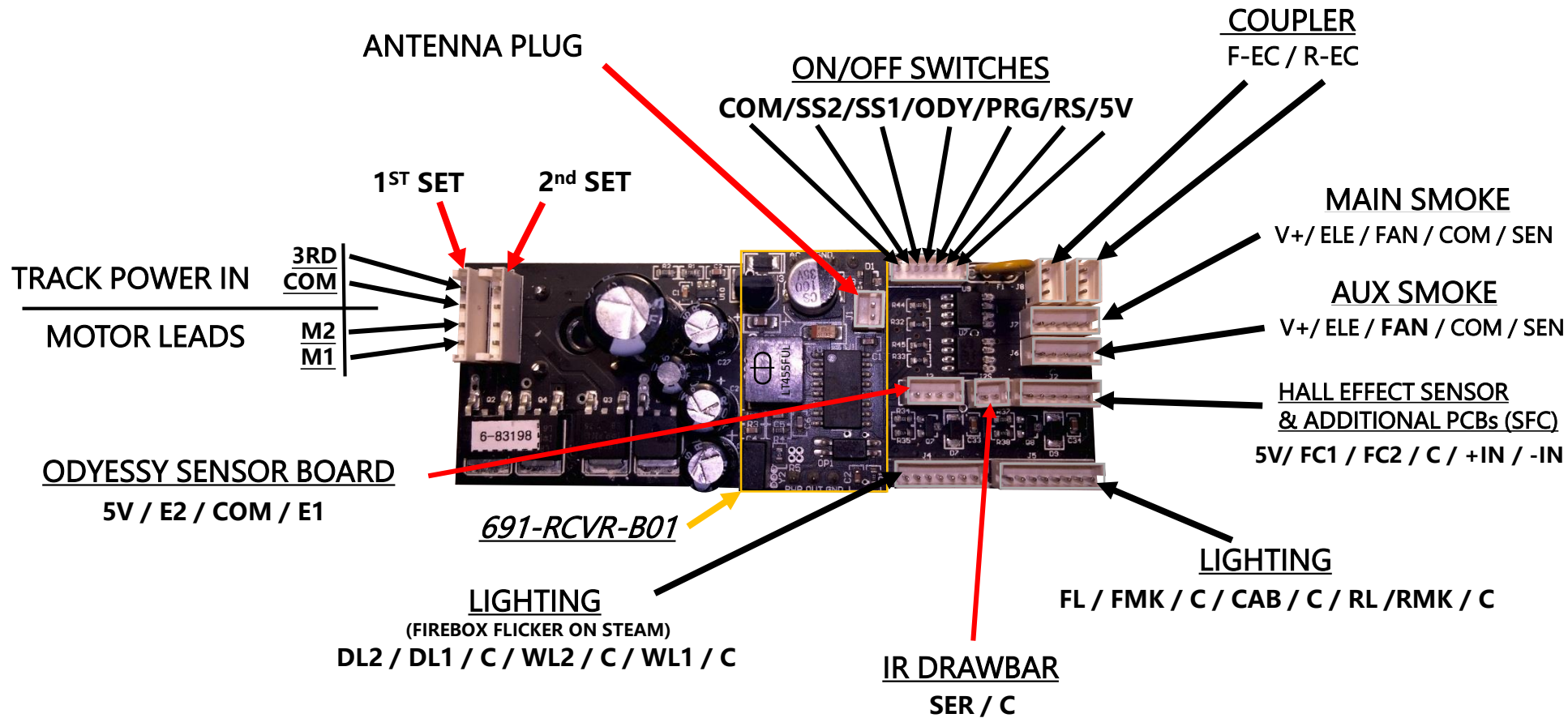

RCMC PIN BREAK DOWN	
ABRV	TERM
3RD	HOT (CENTER RAIL PICK UP)
COM	COMMON GROUND
M1	MOTOR LEAD 1
M2	MOTOR LEAD 2
SS1	SMOKE SWITCH 1
SS2	SMOKE SWITCH 2
ODY	ODYSSEY SWITCH
PRG	PROGRAM/RUN SWITCH
RS	RAIL/SIGNAL SOUNDS SWITCH
5V	5 VOLTS +
F-EC	FRONT ELECTRO COUPLER
R-EC	REAR ELECTRO COUPLER
V+	POSITIVE OUTPUT VOLTAGE
ELE	HEATING ELEMENT
FAN	SMOKE FAN MOTOR
SEN	HEAT SENSOR RESISTOR
FC1	?
FC2	?
FL	FRONT LIGHT
FMK	FRONT MARKER LIGHTS
RMK	REAR MARKER LIGHTS
CAB	CAB LIGHT
RL	REAR LIGHT
SER	SERIAL DATA LINE
DL1	DITCH LIGHT 1
DL2	DITCH LIGHT 2
WL1	WORK/GROUND LIGHT 1
WL2	WORK/GROUND LIGHT 2
C	COMMON GROUND
+IN	?
-IN	?
E1	?
E2	?

NOTE:

Each RCMC board is programmed for the specific product it came from. Make sure when ordering a new RCMC board, it has the correct part number for the item you are repairing.

Diagram Perfected By:
Bruk Bannister with help from **Lionel LLC.**

Revised January, 2017

NOTES:

• (C)= COMMON GROUND TO BOARD NOT CHASSIS GROUND

RCMC Wiring Diagram

(Steam) WITH THERMISTOR

WIRE COLOR WILL VARY

Diagram 5

NOTE:
LED's are Polarity Sensitive.
If installed backwards they
will not work.

NOTE:
Each RCMC board is programed for the
specific product it came from. Make
sure when ordering a new RCMC board,
it has the correct part number for the
item you are repairing.

A FEW STEAM MODELS WILL
HAVE TWO MOTORS. BUT
TYPICALLY ONE IS USED.
CONSULT DIESEL DIAGRAM
FOR WIRING TWO MOTORS.

(Hot)
Center Rail Pick Up

TRACK
CHASSIS
GROUND

(TYPICALLY) GRAY

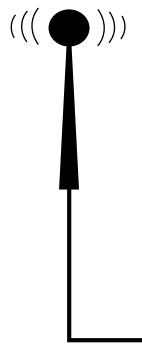

ANNTENA

SMK AUX SMK MAIN ODY ON/OFF PRG/RUN

IR Drawbar
Transmitter

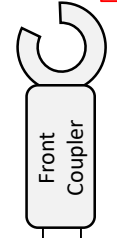

(IF EQUIPPED)

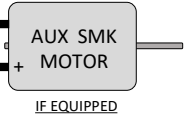
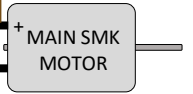
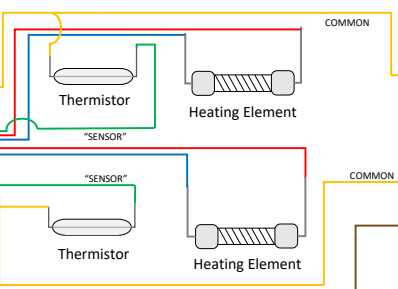
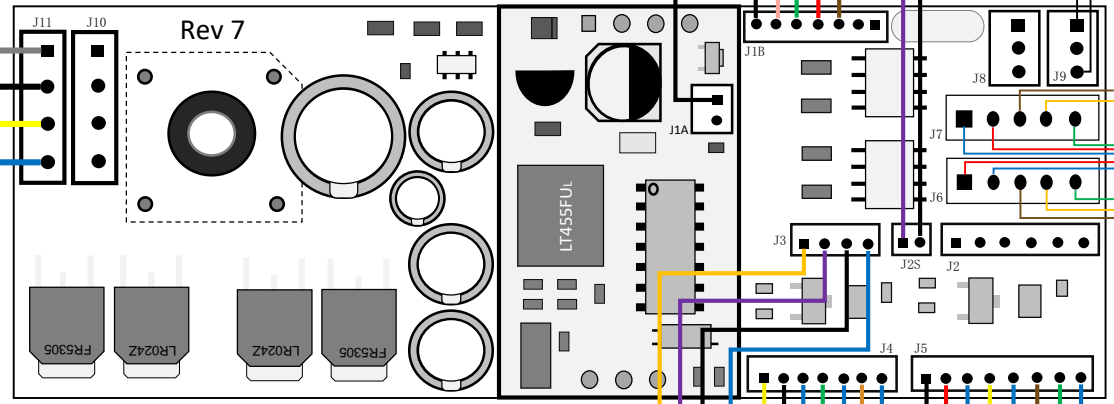

IF EQUIPPED

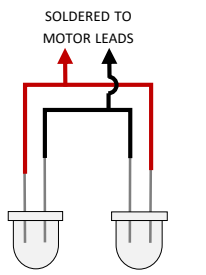
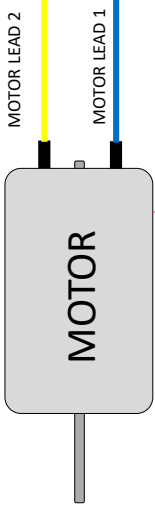

ASH PAN GLOW LIGHTS
(IF EQUIPPED) THERE IS A SET ON THE
LEFT AND RIGHT SIDE OF MOTOR.

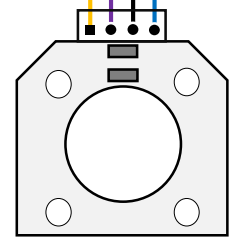

Motor Sensor Board

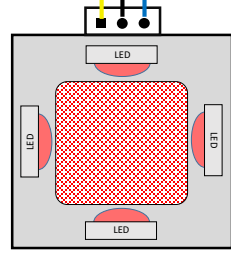

Flickering Fire Box
PCB

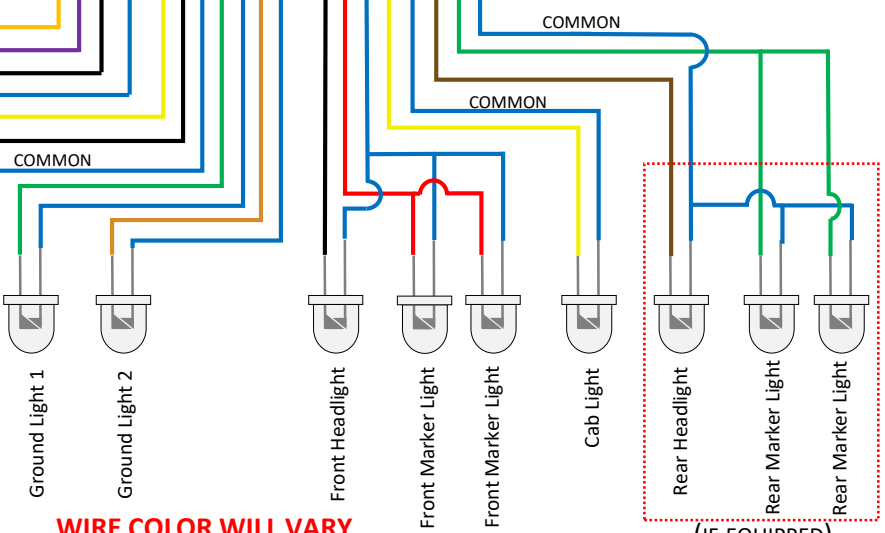

"Special" Lighting
Output location may
vary per model for
certain lighting features
such as:

- MARS Lights
- Strobe Lights
- Emergency Lights
- Warning Lights
- Flashing Beacons
- Ground Lights
- Work Lights
- Number Boards
- Lit Gauges

IT IS RECOMMEND TO TRACE THE
WIRES FROM THE LED TO THE PIN
OUTS ON THE BOARD

WIRE COLOR WILL VARY

(IF EQUIPPED)

RCMC Wiring Diagram

(Steam with Tether) WITH THERMISTORS

WIRE COLOR WILL VARY

Diagram 6

NOTE:
The "PCB female Plug end" is used for a visual reference only, the wire location on PCB might vary. Always test pin outs with a meter to avoid damage to both the RCMC board and RS-LITE board.

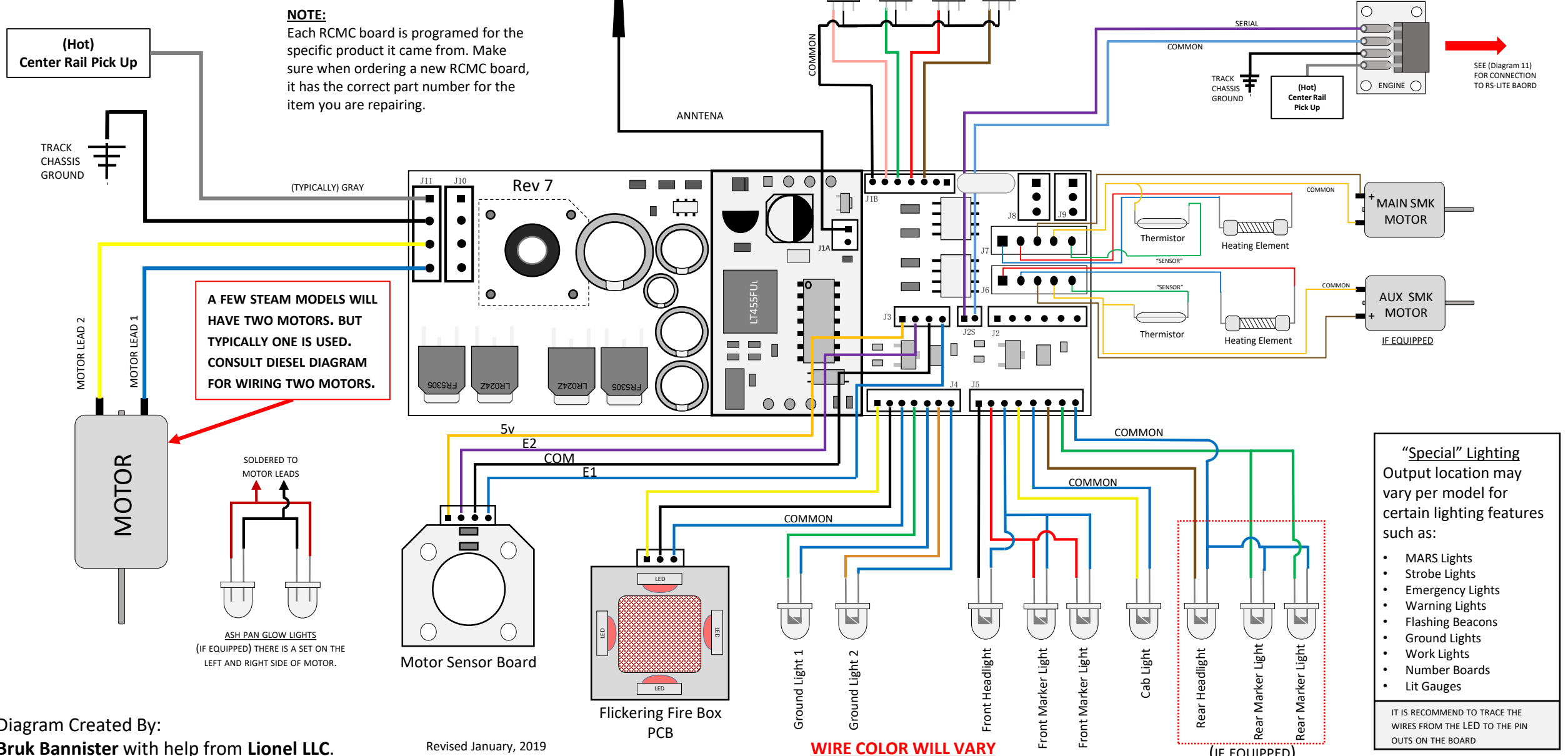

RCMC Wiring Diagram

(Diesel/Electric) WITH THERMISTORS

Diagram 7

NOTE:
LED's are Polarity Sensitive.
If installed backwards they
will not work.

NOTE:
Each RCMC board is programed for the
specific product it came from. Make
sure when ordering a new RCMC board,
it has the correct part number for the
item you are repairing.

(Hot)
Center Rail Pick Up

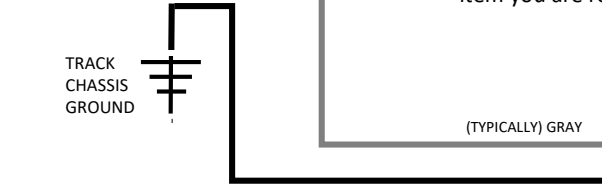

WIRE COLOR WILL VARY

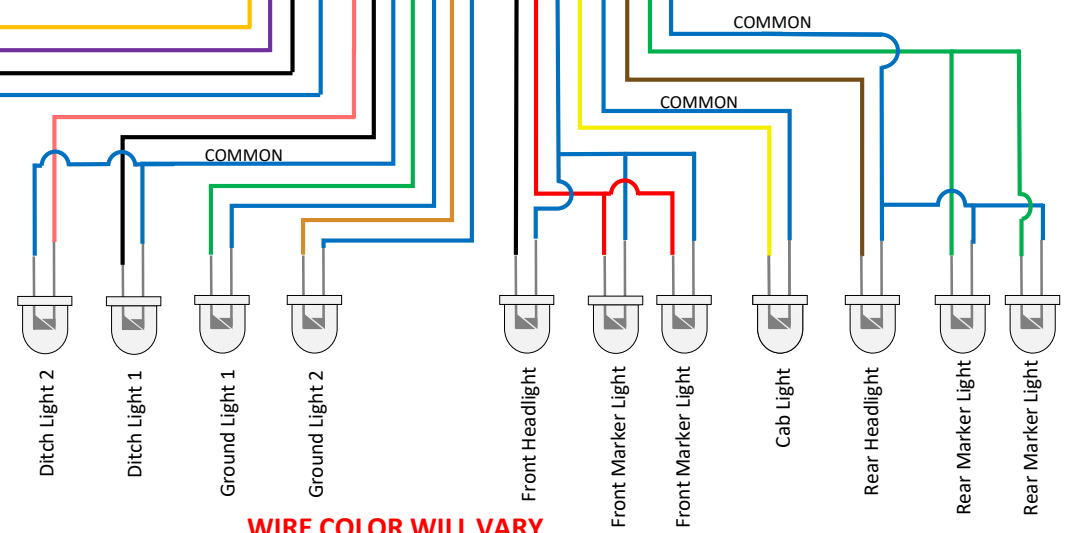
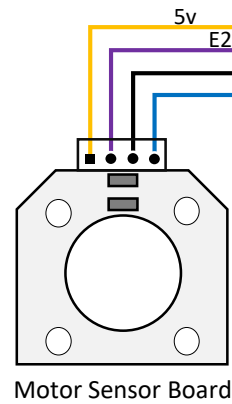
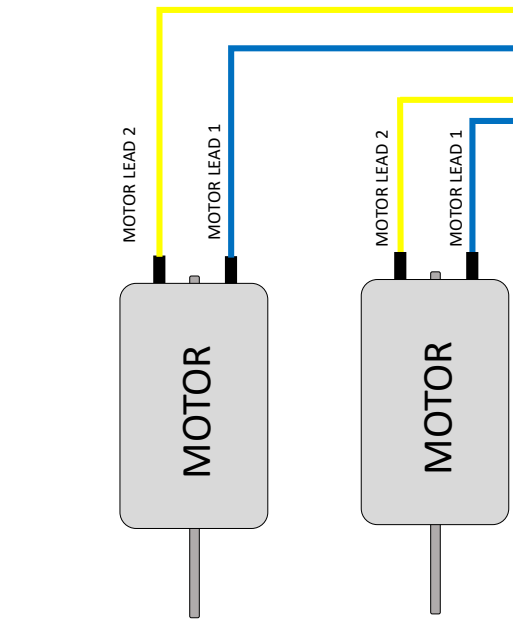
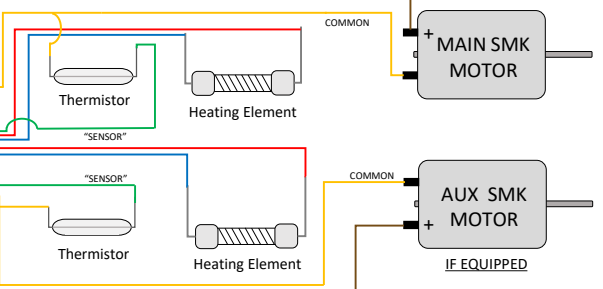
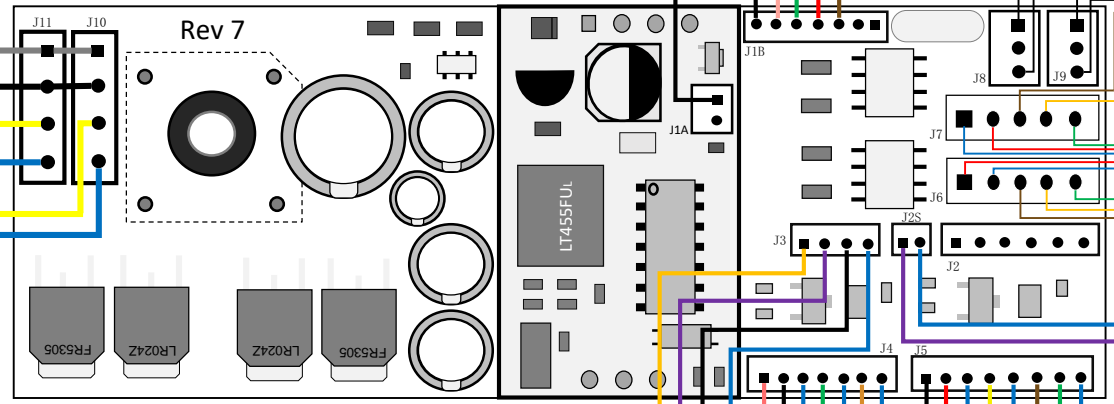
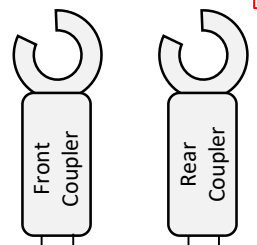
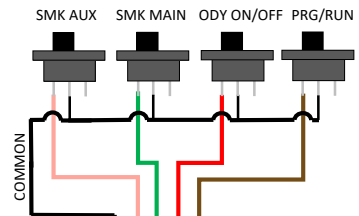
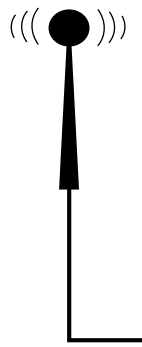

"Special" Lighting
Output location may
vary per model for
certain lighting features
such as:

- MARS Lights
- Strobe Lights
- Emergency Lights
- Warning Lights
- Flashing Beacons
- Ground Lights
- Work Lights
- Number Boards
- Lit Gauges

IT IS RECOMMEND TO TRACE THE
WIRES FROM THE LED TO THE PIN
OUTS ON THE BOARD

WIRE COLOR WILL VARY

RCMC Wiring Diagram

(Non-Powered Units) WITH THERMISTORS

WIRE COLOR WILL VARY

Diagram 8

NOTE:
Each RCMC board is programmed for the specific product it came from. Make sure when ordering a new RCMC board, it has the correct part number for the item you are repairing.

(Hot)
Center Rail Pick Up

TRACK
CHASSIS
GROUND

(TYPICALLY) GRAY

NOTE:
LED's are Polarity Sensitive. If installed backwards they will not work.

"Special" Lighting
Output location may vary per model for certain lighting features such as:

- MARS Lights
- Strobe Lights
- Emergency Lights
- Warning Lights
- Flashing Beacons
- Ground Lights
- Work Lights
- Number Boards
- Lit Gauges

IT IS RECOMMEND TO TRACE THE WIRES FROM THE LED TO THE PIN OUTS ON THE BOARD

NOTE:
Not all lighting features are used in non-powered unit.

NOTE:
Hall Effect Sensors come in different shapes, sizes and part numbers. A generic shape is used for visual aid. Check the parts site for your specific item.

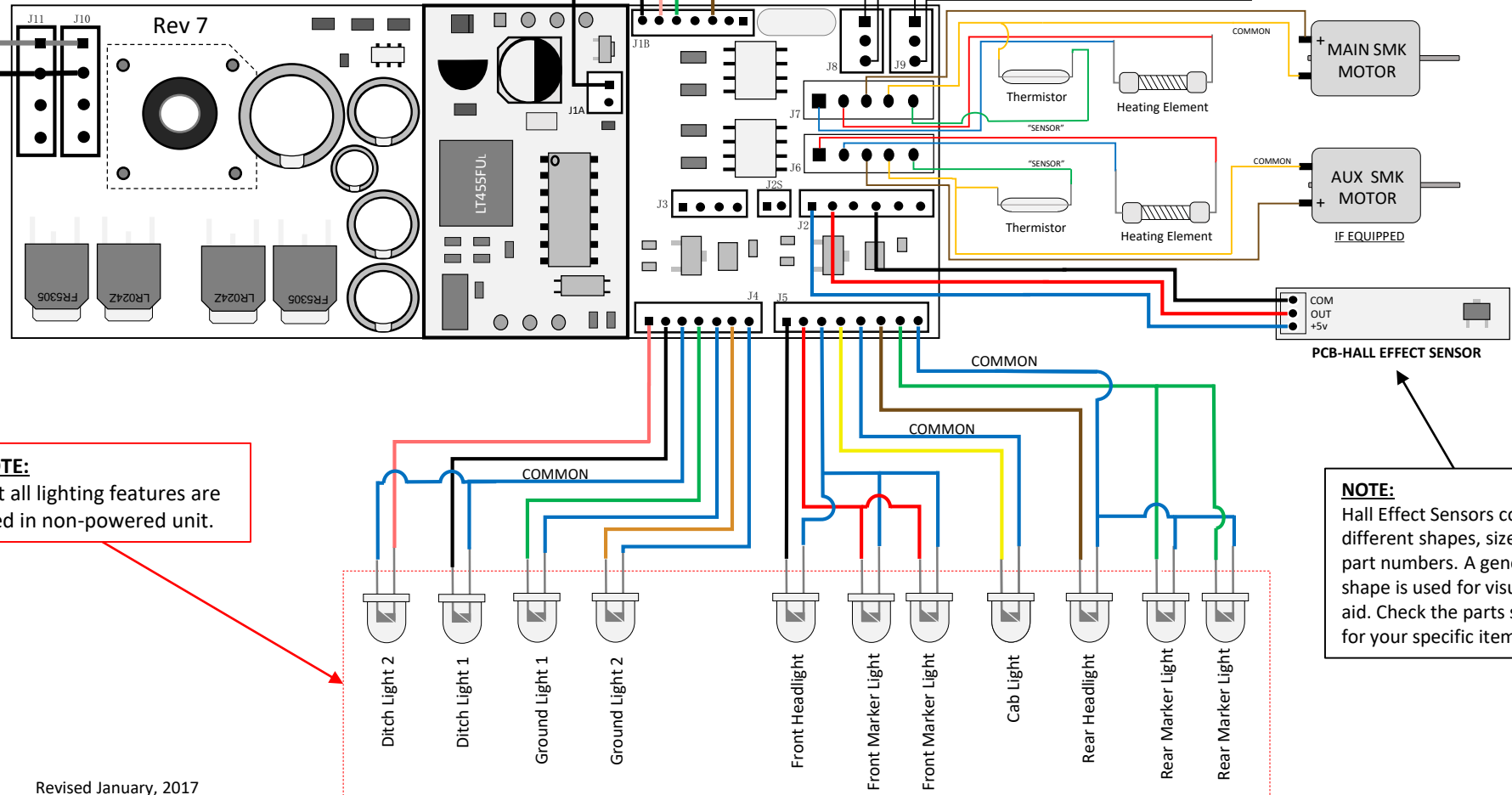

LEGACY BLUETOOTH RECEIVER

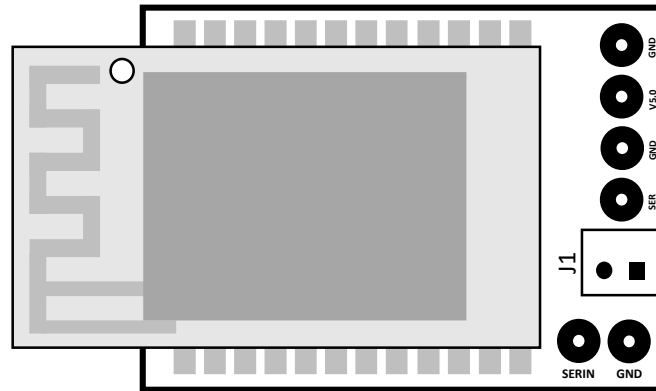

BLUETOOTH RECIEVER BREAK DOWN

NOTE:

Each board is programed for the specific product it came from. Make sure when ordering a new Bluetooth board, it has the correct part number for the item you are repairing. There should be a sticker with the items product number starting with a (6 -??????)

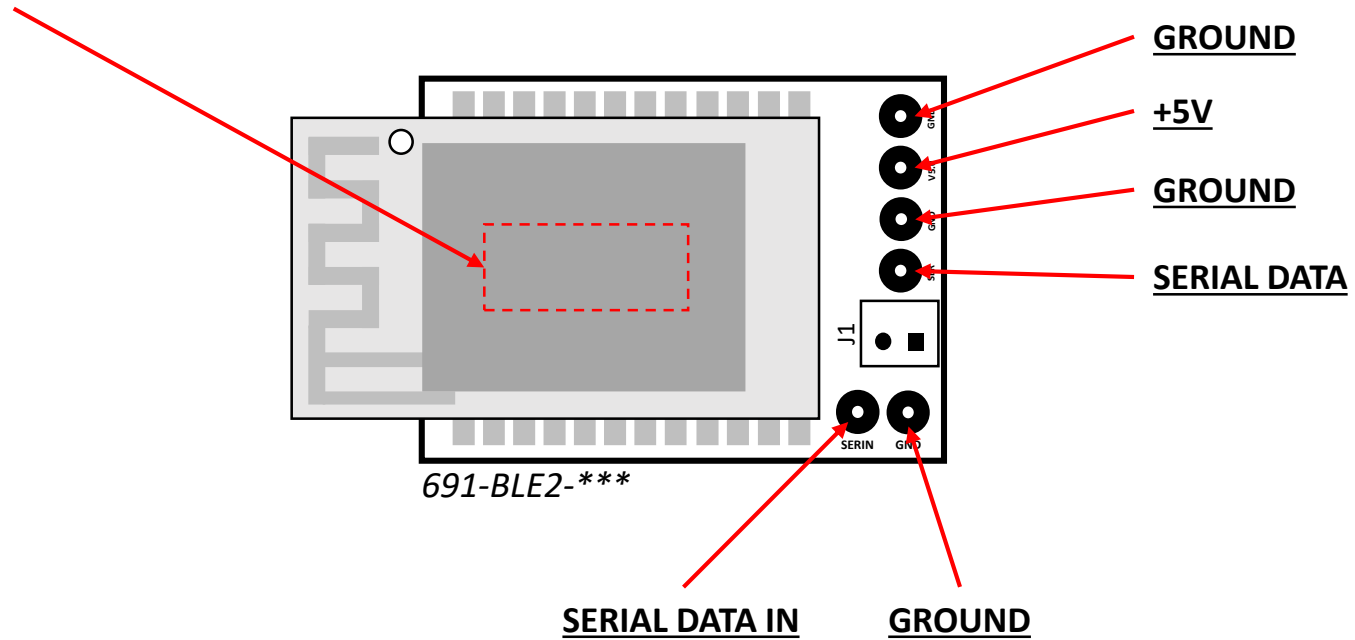

Bluetooth Receiver Diagram

(Steam and Diesel locomotives)

WIRE COLOR WILL VARY

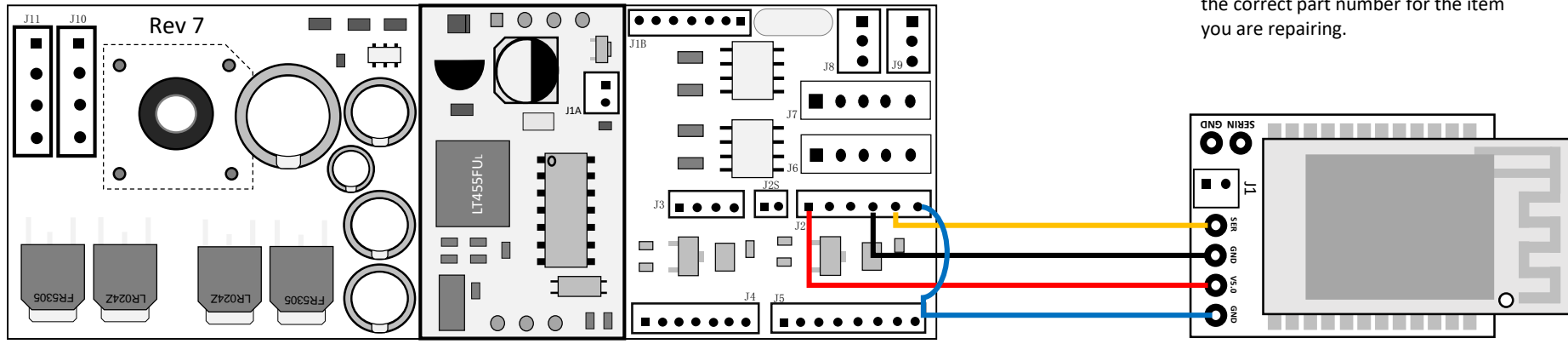

RCMC

BLUETOOTH RECIEVER

NOTE:
Each board is programmed for the specific product it came from. Make sure when ordering a new Bluetooth board, it has the correct part number for the item you are repairing.

RailSounds LITE

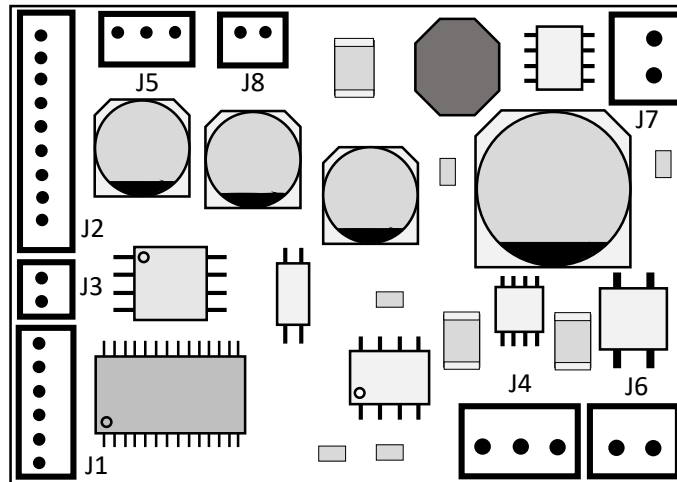

RAILSOUNDS LITE PLUG BREAK DOWN

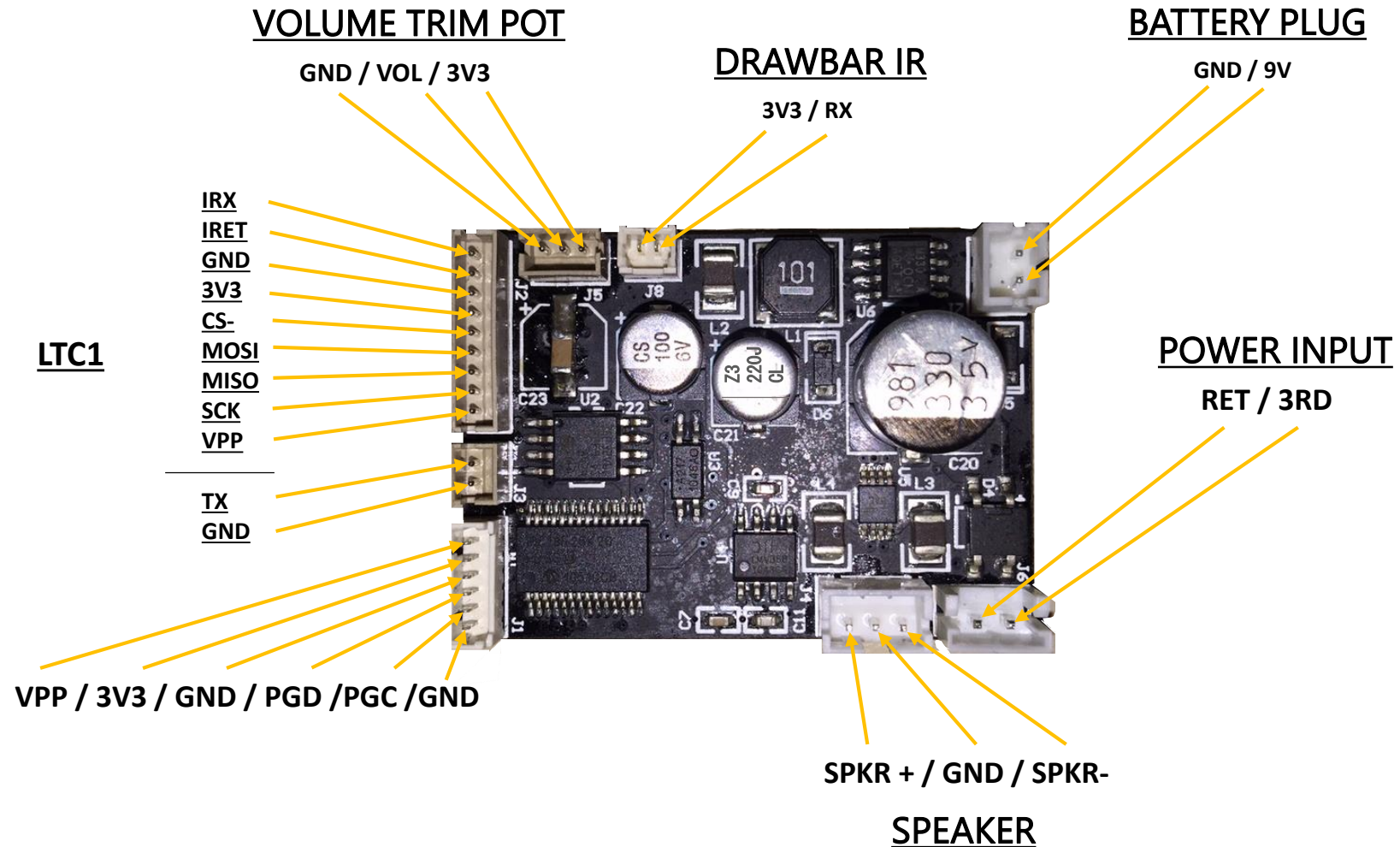

WIRE COLOR WILL VARY

RAILSOUNDS LITE Wiring Diagram (Diesel/Electric)

Diagram 9

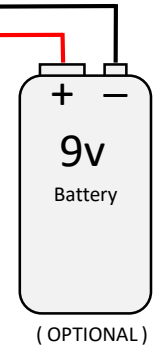
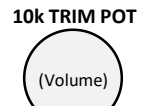
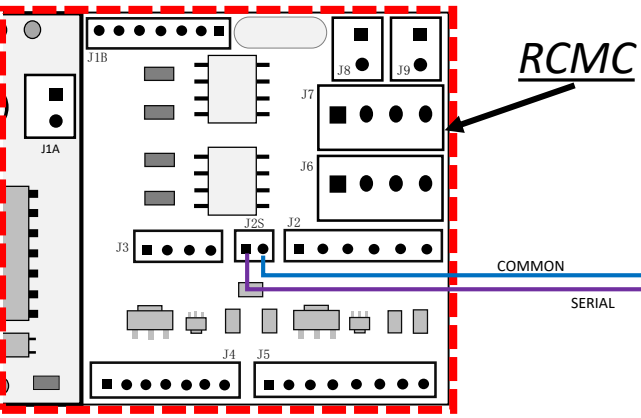

NOTE:
Each sound board is programmed for the specific product it came from. Make sure when ordering a new sound board, it has the correct part number for the item you are repairing.

TRACK I.R. DECODER/DRIVER BOARD

- LTC1 Board controls lighting, coupler functions and communicates with LCS track.

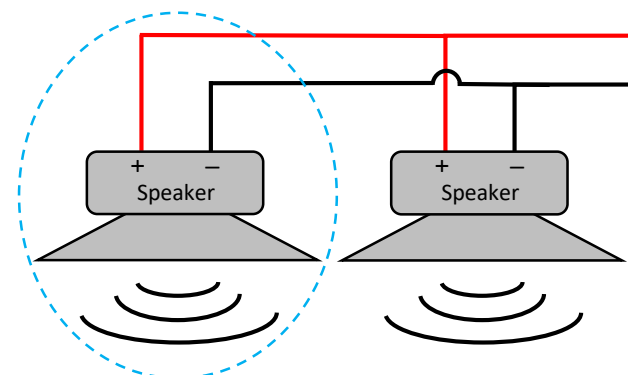
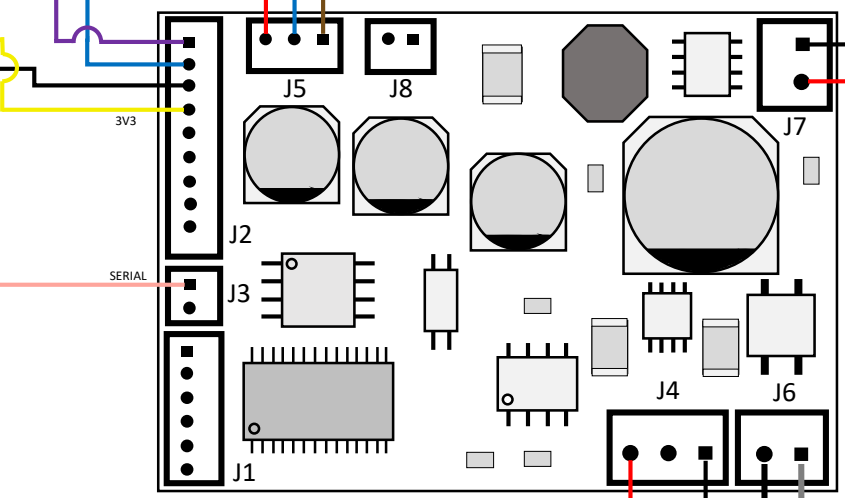
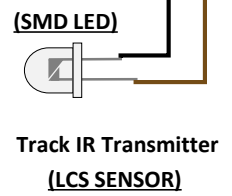
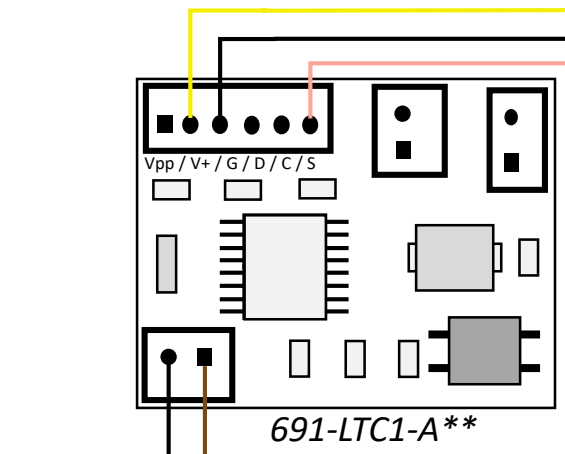

IF EQUIPPED WITH TWO SPEAKERS

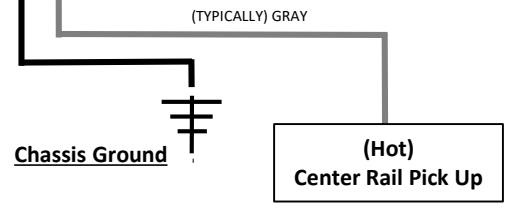

WIRE COLOR WILL VARY

WIRE COLOR WILL VARY

RAILSOUNDS LITE Wiring Diagram

(Steam Tender)

Diagram 10

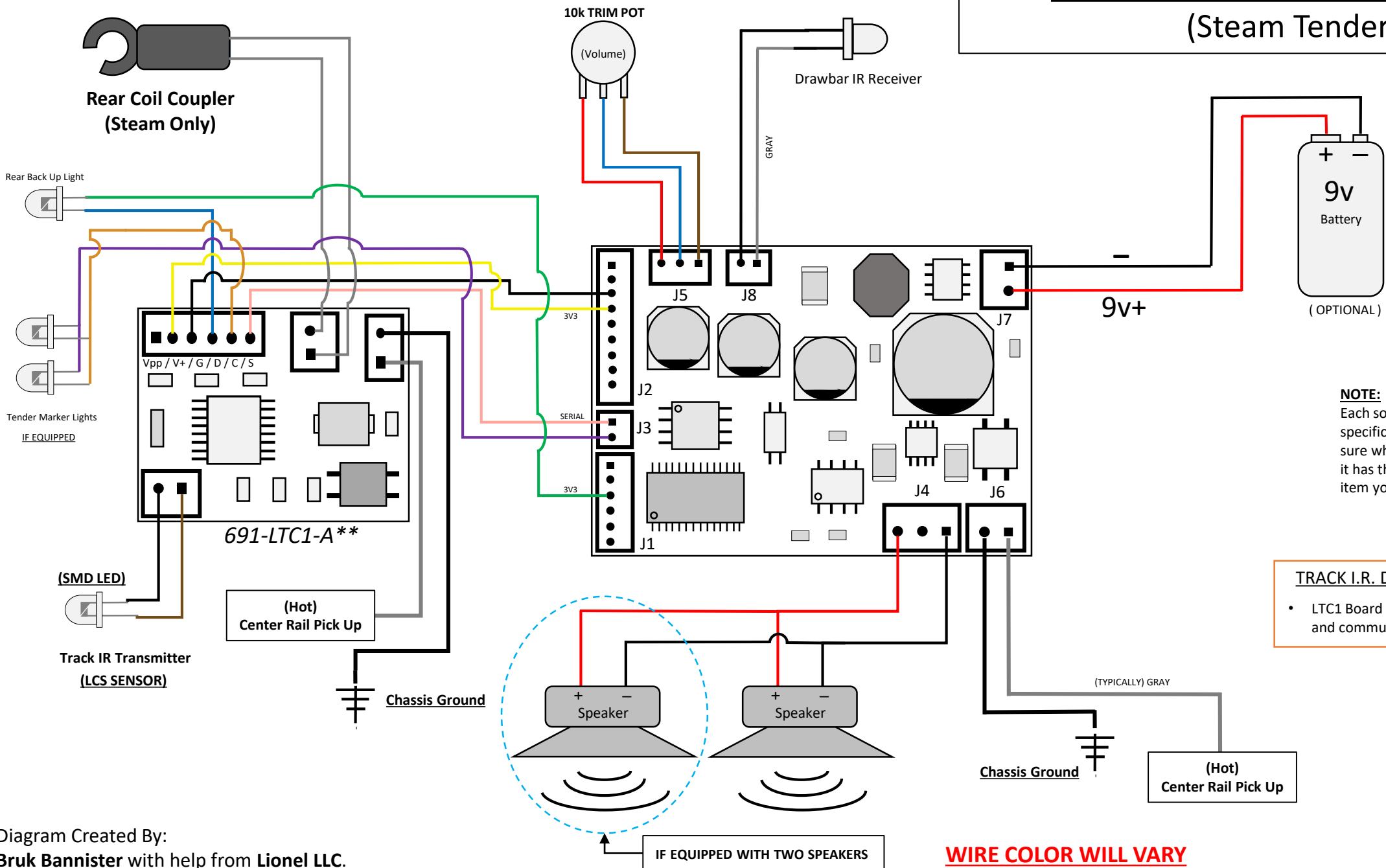

NOTE:
 Each sound board is programmed for the specific product it came from. Make sure when ordering a new sound board, it has the correct part number for the item you are repairing.

TRACK I.R. DECODER/DRIVER BOARD

- LTC1 Board controls lighting, coupler functions and communicates with LCS track.

WIRE COLOR WILL VARY

IF EQUIPPED WITH TWO SPEAKERS

WIRE COLOR WILL VARY

RAILSOUNDS LITE Wiring Diagram (Steam Tender with Wire Tether)

Diagram 11

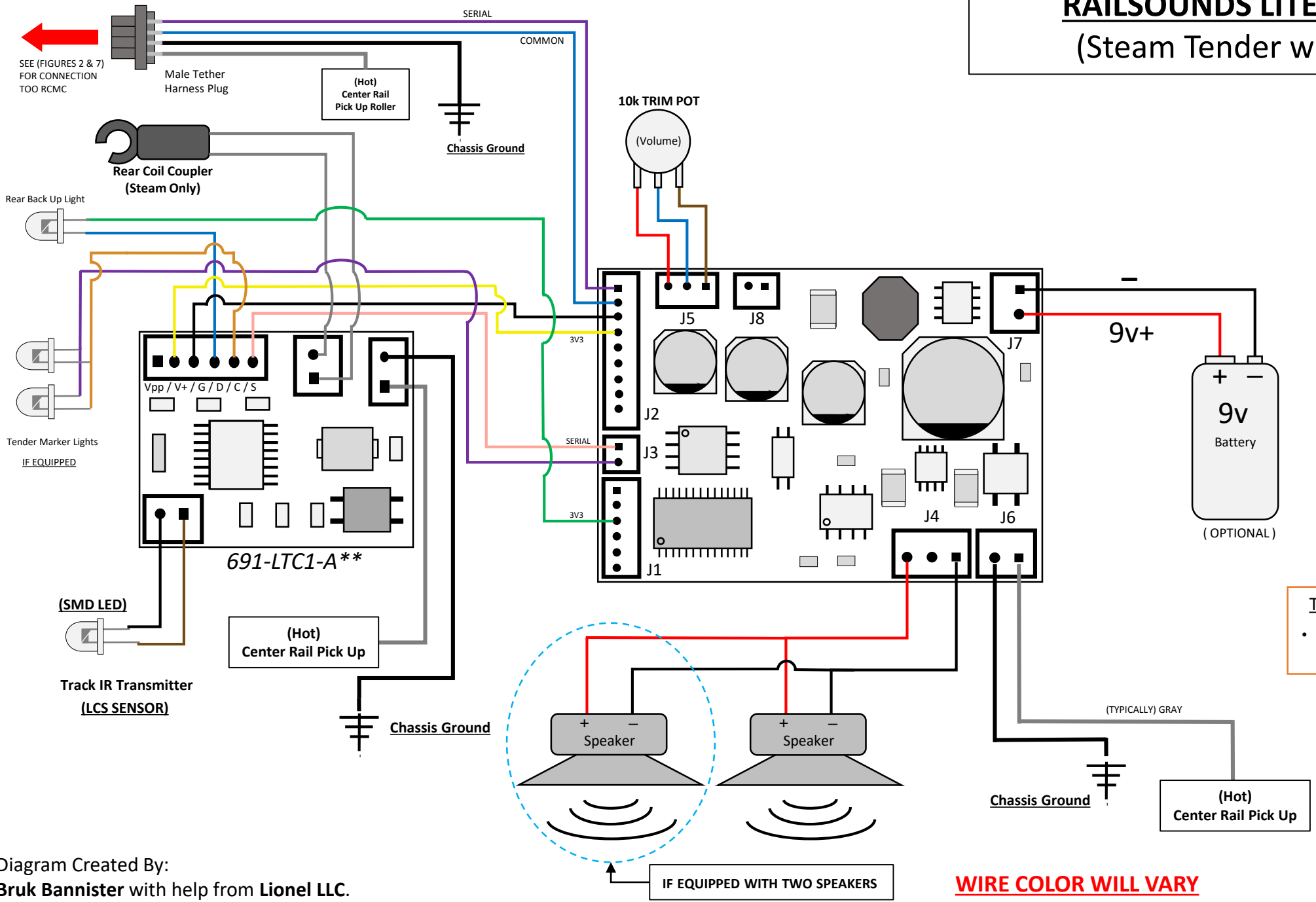

NOTE:
The "Male Harness plug" is used for a visual reference only, the wire location might vary. Always test pin outs with a meter to avoid damage to both the RCMC board and RS-LITE board.

NOTE:
Each sound board is programmed for the specific product it came from. Make sure when ordering a new sound board, it has the correct part number for the item you are repairing.

TRACK I.R. DECODER/DRIVER BOARD

- LTC1 Board controls lighting, coupler functions and communicates with LCS track.

WIRE COLOR WILL VARY