

Chuff-Generator

The Chuff-Generator (C-G) is an add-on electronic module for TMCC controlled steam locomotives to replace mechanical chuff switches. It also supplies a programmable chuff rate locked to driver rotation. The C-G can be installed in factory TMCC locomotives or TMCC upgraded locomotives. An optional output for ground light control is provided; the ground lights will be extinguished at approximately 10 MPH and lit at other times. The MPH calculation is based on an average gear ratio and driver diameter and may vary between models. The C-G is fabricated on a printed circuit board with the dimensions of 1.3" x 0.4" in size. The overall height including components is approximately 0.125".

Conn	Pin	Description of Function
J1	1	Calibration Jumper
J1	2	Calibration Jumper
J2	1	+5VDC Power Input
J2	2	Chuff output
J2	3	Frame Ground (-5VDC)
J3	6	Ground Light Control Output

Three connection areas totaling six connections are provided for connecting the C-G into the locomotive. The board is supplied without wires. The intent is the installer will solder the correct length wires required for the particular installation. If desired, you can ship the motor to us and we'll mount the C-G and attach the wires and mount the sensor with the correct spacing. If you desire this service, contact us at the email address at the end of this document. J3 has 6 connections, but pins 1-5 are for factory test only and should not be used. The J1 pins are used only for initial chuff rate calibration and are typically connected using jumper clips or the like for a temporary connection. For an installation using the Super-Chuffer, the 5VDC is supplied by the Super-Chuffer board. For a stand-alone installation not using the Super-Chuffer, the user has to supply

a suitable 5VDC power supply that has a 30ma current output. The Chuff output (J2 pin 2) is wired to the chuff input of the existing TMCC electronics and replaces the previous chuff switch which must be disconnected from the chuff input.

The C-G is mounted using a small mounting plate with a curved side that is glued to the drive motor to position the C-G sensor correctly over the flywheel. The exact position on the motor will largely be determined by the clearance to the boiler shell. Before mounting the C-G, clean the flywheel with alcohol or a similar solvent, then apply the tach tape to the flywheel. If the stripes don't match at the end of the tape, it's best to black out a narrow stripe and make a larger black stripe. The stripe count or width is not critical to the calibration or operation of the C-G.

The installation for smaller motors such as the Mabuchi motor found in smaller steamers is illustrated below. These will require the sensor board be spaced off the motor with a stack of the supplied spacers to provide the correct 1mm spacing for the tach reader sensor. Each spacer is glued to the stack. On the left is the curved C-G mount glued to the motor. On the right is the completed mount showing the additional spacers used to achieve the 1mm spacing of the tach reader sensor from the flywheel tach tape. Note that the tach sensor has been soldered flush to the board as the flywheel is close to the diameter of the motor. For this installation, the sensor is soldered to the board before mounting as adjusting the spacing after mounting is not required.

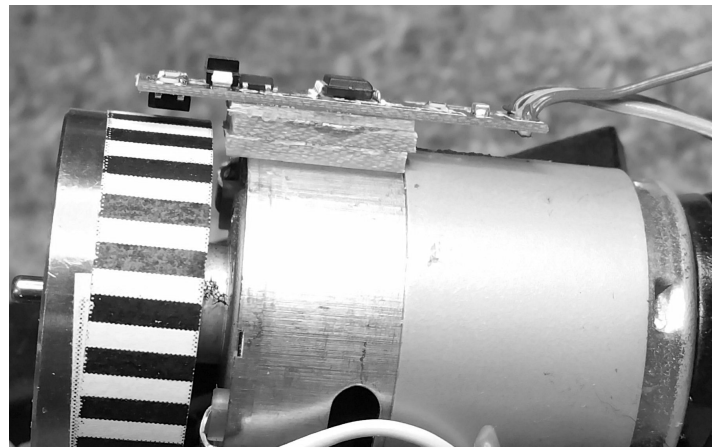

The second installation type is for larger motors, such as the Pittman, found in larger scale steamers. For a large motor install the same curved base is used to mount the C-G to the motor. The difference is that additional spacers are not used as the flywheel is typically smaller than the motor so the sensor will have to be extended to achieve the desired 1mm spacing from the flywheel tach tape. The following illustration shows this type of installation.

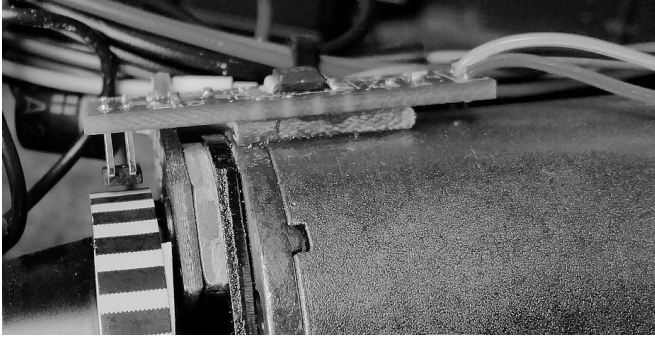

The C-G is mounted on the curved mount glued to the motor. As you can see, there are no additional spacers. Note also that the sensor is extended from the board to achieve the 1mm spacing in contrast to the previous installation where the sensor was soldered flush to the board. For the larger motor installation, the sensor is inserted into the mounting holes but NOT soldered until the C-G board is mounted. This is important as you will have to first attain the proper position of the sensor above the flywheel before soldering it in place. Take note of the trimming of the wires soldered to the board, they must NOT project far enough down to touch the motor casing. Some insulating tape on the motor under the terminals is a useful precaution.

The tach sensor is supplied not soldered to the board as the exact positioning will vary based on the installation type. It is VERY important to orient the sensor properly. Take note of the small corner cut on the sensor, and the square pad on the C-G board. These MUST be aligned or the sensor will not function, see arrow in figure on the right. Also take note that the sensor is mounted on the opposite side of the C-G board from the rest of the components as it has to face the flywheel when the board is attached to the motor. It is very important to get the sensor spacing correct at 1mm +/- about .2mm for reliable operation. If the sensor is too close or too far from the flywheel, you will have unreliable operation or no chuffs at all.

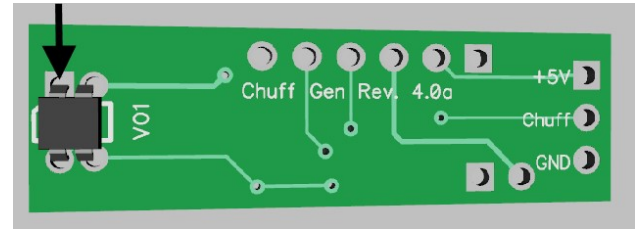

NOTE: Due to an unfortunate production issue with the silkscreen on the Rev. 4.0a C-G, many of the boards will not have the proper registration of the bottom silkscreen on the boards. This does not affect the functionality of the C-G.

Once the C-G and sensor correctly positioned and mounted, the next step is testing if the sensor can properly read the tach strip. As shipped the C-G is set to power up in sensor test mode. In this mode, each time the stripe is sensed, the LED will go on and when you rotate past the stripe, the LED will go off. This allows you to verify that the sensor is reading the stripe reliably before you attempt a calibration.

If later after a calibration or attempted calibration you'd like to return to the sensor test mode, use the following procedure.

1. Connect a jumper cable between the two J1 pads on the C-G.
2. Apply 5VDC power to the C-G board; note that the red LED at D1 is illuminated.
3. Remove the jumper cable between the two J1 pads without moving the flywheel.
4. Remove 5VDC power from the C-G board.

This returns the C-G to sensor test mode, the next time you power up, it will again be reading the sensor and turning the LED on and off as the stripes pass under the sensor.

Once the sensor operation has been verified, you can proceed to calibration of the C-G.

1. Connect a jumper cable between the two J1 pads on the C-G.
2. Apply 5VDC power to the C-G board; note that the red LED at D1 is illuminated.
3. Rotate the motor flywheel until the drive wheels have move the desired distance between chuffs. For four chuffs/rev. that would be $\frac{1}{4}$ of a turn of the drive wheels. For two chuffs/rev that would be $\frac{1}{2}$ of a turn of the drive wheels.
4. Remove the jumper cable between the two J1 pads.
5. Remove 5VDC power from the C-G board.

This completes the calibration steps. If it is desired to recalibrate at any time, just repeat the above calibration steps.

The optional ground light output is a solid state switch to frame ground with a diode to protect against reverse voltage. Typical use will be to connect the ground lights to track power with appropriate current limiting and/or voltage rating of the lights. The ground light output is capable of switching up to $\frac{1}{2}$ an amp of current. Any load in excess of this value will likely cause the ground light output to fail and can destroy the C-G. For 18V track power, a 12V incandescent bulb or bulbs is appropriate. For LED's, current limiting resistors from track voltage, assuming 12 volts applied voltage is appropriate.

For additional information or technical support, please contact us via email at: chuff-generator@will-enterprises.com

Super-Chuffer II & Chuff Generator Example

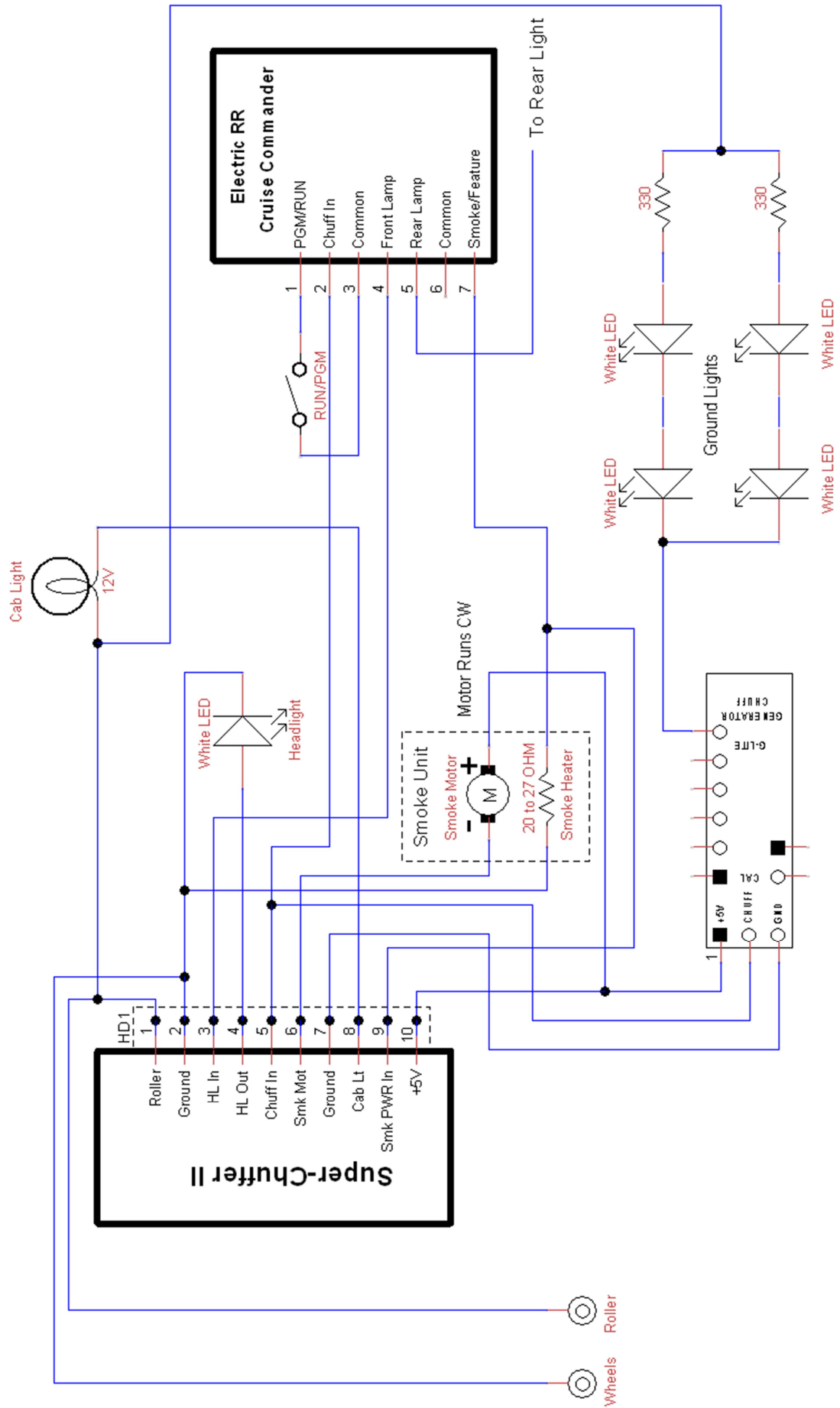

Figure 1 Chuff-Generator with Super-Chuffer Wiring Example