

TPC3000

---

TRACK POWER CONTROLLER

REFERENCE MANUAL  
VERSION 1.2



# **TABLE OF CONTENTS**

<b><u>INTRODUCTION</u></b>	<b><u>1</u></b>
<b><u>SPECIFICATIONS</u></b>	<b><u>2</u></b>
PHYSICAL	2
ELECTRICAL RATINGS	2
MATERIALS NEEDED	2
FEATURES	2
<b><u>GENERAL INFORMATION</u></b>	<b><u>3</u></b>
TERMS	3
COMMON POINTS	3
IMPORTANT KEYS	4
<b><u>WIRING CONNECTIONS</u></b>	<b><u>5</u></b>
POWER IN	5
TRACK OUT	5
COMM	7
<b><u>CONNECTING THE TPC TO THE COMMAND BASE</u></b>	<b><u>8</u></b>
<b><u>GENERAL OPERATION</u></b>	<b><u>9</u></b>
RUN / PROGRAM SWITCH	9
USE OF LED LIGHTS	9

<b><u>SETTING OPERATION MODES</u></b>	<b><u>11</u></b>
GENERAL OVERVIEW	11
COMMAND MODE	11
POWER ON COMMAND MODE	12
POWER OFF IN COMMAND MODE	12
LED FUNCTION IN COMMAND MODE	12
SAVING THE SETTING FOR THE NEXT TIME OF OPERATION	12
CONVENTIONAL MODE	13
SETTING THE TPC3000 ADDRESS	14
<b><u>USING QSI/MTH FEATURES WITH CAB-1</u></b>	<b><u>15</u></b>
POWERING UP	15
PROGRAMMING QSI/MTH	16
<b><u>TROUBLE SHOOTING GUIDE</u></b>	<b><u>17</u></b>
<b><u>WIRING EXAMPLES</u></b>	<b><u>19</u></b>
SIMPLE WIRING	19
CONNECTING TWO POWERHOUSES TO SUPPLY 300 WATTS OF POWER TO YOUR TRACK!	20
WIRING TWO OR MORE SEPARATE BLOCKS OR TRACK	21
<b><u>ADDITIONAL INFORMATION AND TECHNICAL SUPPORT</u></b>	<b><u>22</u></b>
<b><u>WARRANTY INFORMATION</u></b>	<b><u>22</u></b>

## ***INTRODUCTION***

---

The TPC3000 Track Power Controller is designed to be used with and is completely compatible with the Lionel Trainmaster Command Control system. The TPC3000 is a direct replacement for the Lionel PowerMaster. Providing solid state speed control up to 300 Watts of output power that controls the voltage to the track. The TPC3000 operates conventional locomotives from a handheld remote like the CAB-1 without the use of decoders. In addition, commands have been added to increase compatibility between Lionel Train Master and the operation of QSI/MTH's E Units.

In command mode the TPC3000 applies full voltage to track allowing command controlled locomotives to operate. This is done through any Lionel Trainmaster compatible hand held such as the Lionel CAB-1. This manual is designed to take you through the basic operation and wiring details of the TPC3000. Please take the time to read this information before attempting to connect it to your layout.

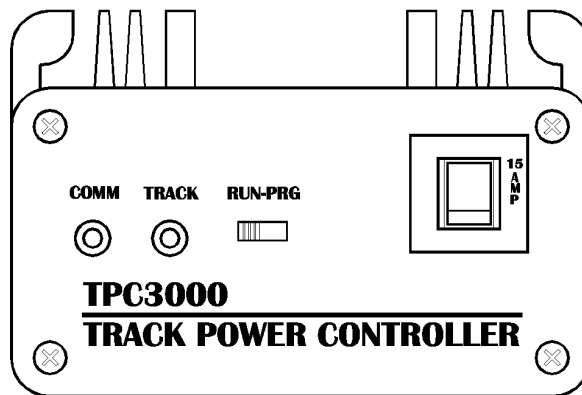

# **SPECIFICATIONS**

---

## **Physical**

Size 6.125" x 3.75" x 2.7"

Metal Enclosure

Regulates the voltage supplied to the track

## **Electrical Ratings**

Maximum Input Voltage 9Volts to 24 Volts AC @ 60 Hz

COMM input signal +/- 12 Volts

Maximum Output Current 15Amp @ 20V or 300 Watts

## **Materials Needed**

Lionel Trainmaster Command Control System

Command Base and CAB-1

Transformer or transformers in combination with the output of up to 300 Watts

Wire, must have a minimum of 16 gauge wire for power and track connections

If connecting two Lionel Powerhouse transformers in parallel you will need a Y cable, IC Controls Part #(ICC3003-6)

## **Features**

300 Watts of track power

Command or conventional operation

2 ½ times greater speed control

Communication and track power indicator

Change from command and conventional operation from the remote

One button programming for QSI/MTH E units

# ***GENERAL INFORMATION***

---

## ***Terms***

Following are specific terms, words, letters and how they are used in the manual:

- DAT: The RED wire connected to the COMM connector
- COMM: Communication terminals
- COM: The green wire connected to the COMM connector
- TRACK OUT A: Lionel terminology for power or hot connection to the center rail
- TRACK OUT U: Lionel terminology for ground or neutral connection to outside rails
- LED: Indicator to let you know the controller is working
- TERMINAL: Connector strip where you connect the wires
- DAISY CHAIN: Linking multiple controllers together to add additional track, switch and accessory modules
- POWER IN HOT: Power side of AC transformer.
- POWER IN NEUTRAL: Common side of AC transformer.

## ***Common Points***

This is a list of the common points and terms that will be used with the TPC3000.

- TPC3000 units are controlled as tracks/trains (TR) or engines (ENG)
- When operated as tracks/trains (TR) up to 10 TPC3000's may be operated through to the CAB-1 remote, utilizing numbers 0-9
- When operated as engines (ENG) up to 100 TPC3000's tracks/trains may be operated through to the CAB-1 remote, utilizing numbers 0-99
- There are two modes of operation styles:
  - Conventional mode: Operates conventional locomotives without decoders supplying variable voltage to the track. This is used to operate older locomotives without decoders and MTH engines
  - Command mode: Operates command controlled locomotives with decoders supplying full voltage to the track. Only Lionel command control equipped locomotives can use this mode

## **Important Keys**

The following is a list of keys that's used from the Lionel CAB-1

- **(AUX1)** Has two functions in conventional mode turns power off to track and enable numeric entry. In command mode this key along with 0 (zero) will shut the power off to the track
- **(AUX2)** Eliminates neutral phase when changing direction
- **(TR)** Selects the TPC3000 as a track/train
- **(ENG)** Selects the TPC3000 as an engine
- **(RED KNOB)** Controls the speed of the locomotive, turned right or clockwise increases the speed, left or counter clockwise decreases the speed of the locomotive
- **(DIR < >)** Used to change direction, removes power and the same voltage is reapplied when released
- **(BOOST)** Increase the power to the track, holding boost button will increase the speed of the loco until the speed limit is reached. When released the speed will go back to normal
- **(BRAKE)** Decrease the power to the track, holding brake button will decrease the speed of the loco to zero. When released the speed will go back to normal
- **(F KEY)** Not used **(R KEY)** Not used
- **(L,M & H)** Use to set the mode and voltage to the track. There are three different settings.
  - **L** Sets to command mode, supplying full input voltage to track
  - **M** Sets to conventional mode and resets speed limit to maximum
  - **H** Sets maximum speed in conventional mode
- **(HALT)** Turns the track power off to all IC Controls products including the TPC3000
- **(SET)** With the run/program switch in the **RUN** position
  - Saves conventional or command mode settings
  - Saves the current speed limit
- **(SET)** With the run/program switch in the **PROGRAM** position
  - Sets the address of the TPC, either 0-9 for **TR** or 0-99 for **ENG**
- **(AUX1) (7)** Sends Program pulse to QSI E units.
- **(AUX1) (8)** Sets track voltage to nominal 8 Volts.
- **(AUX1) (9)** Sets track voltage to full.



# **WIRING CONNECTIONS**

---

## **Power In**

The power connections to the TPC3000 are located on the back panel and are marked as POWER IN. This is the AC power that comes from the transformer that will supply the power to the track. More than one transformer may be placed in parallel provided the outputs are phased correctly. Two powerhouses may be joined together with our readily available cable Part # ICC3003-6, to supply the maximum power to the track.

The input power should be between 12 and 20 Volts AC and have the capacity of supplying up to 15 Amps to utilize the maximum capacity of the TPC3000. If less than 15 amps is supplied, the TPC3000 will supply the maximum amount of input power.

Two connections are required between the TPC3000 and a transformer:

- The first connection to the TPC3000 is the HOT terminal. It is connected to the HOT side of the transformer. If using the IC Controls cable the Black wire is the HOT.
- The second connection is the NEUTRAL terminal. It is connected to the NEUTRAL terminal or common side of the transformer. If using the IC Controls cable the White wire is the NETRUAL.

**WARNING! When wiring the TPC3000 to the transformer and the track you must use at least 16-gauge wire or higher.**

## **Track Out**

The next connections will be from the TRACK OUT terminals on the back panel. The track power output is the regulated AC voltage supplied to the track. Two connections are required between the TPC3000 and the track:

- The **first** connection to the TRACK OUT is the U neutral, the neutral side of the terminal. This connection will go to the neutral connection or the outside rails of the track. A wire should also be connected between this terminal and the U terminal of the command base. Please reference diagram on the following page. The **second** connection to the TRACK OUT

is A power, the power side of the terminal. It is connected to the power side or center rail of the track.

The following diagram is the basic wiring for the system.

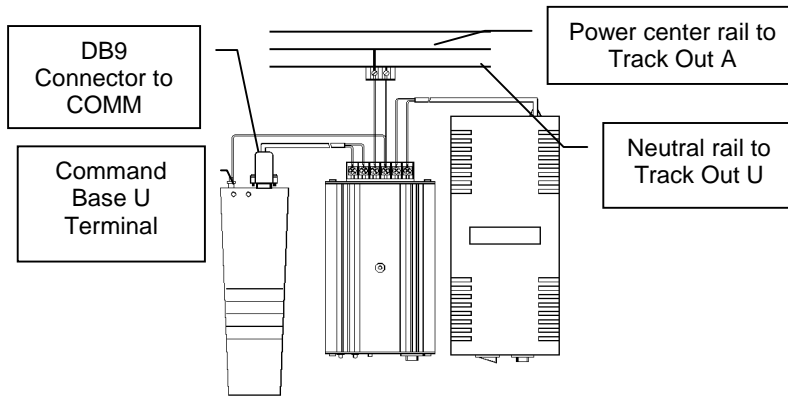

This diagram explains the connections to the back of the TPC3000.

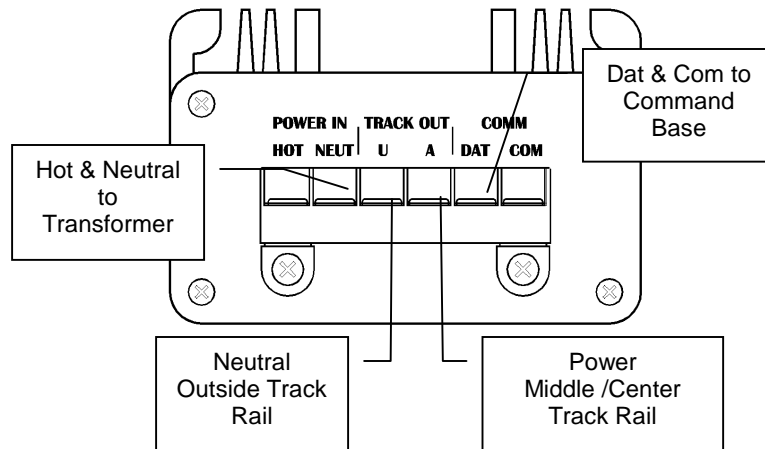

## COMM

The COMM connections on the TP3000 are located on the back right side of the TPC3000 and are marked as connector terminal COMM. These connections supply the communication or COMM to each ALC3000 family member. It tells the controller what you want to do.

Two connections are needed between the TPC3000 and the Lionel Command Base. To make these connections, you will need a cable with a DB9 connector on one end. The interface cable plugs into the Lionel Command Base connector marked computer. IC Controls can provide ready to use cables for connecting the entire ALC3000 Family together. You may purchase these cables by ordering part #ICC3001-6 or -20 depending on length. If using other ALC3000 family products jumper or daisy chain these connections, connecting DAT to DAT - COM to COM.

- The first connection is the DAT (DATA) connection. This would be the red wire of the IC controls ICC3001 cable.
- The second connection is the COM (Common wire of the communication port) connection. This would be the green wire of the IC controls ICC3001 cable.

Making your own cable is explained in detail under CONNECTING THE CABLE FROM THE TPC3000 CONTROLLER TO THE COMMAND BASE.

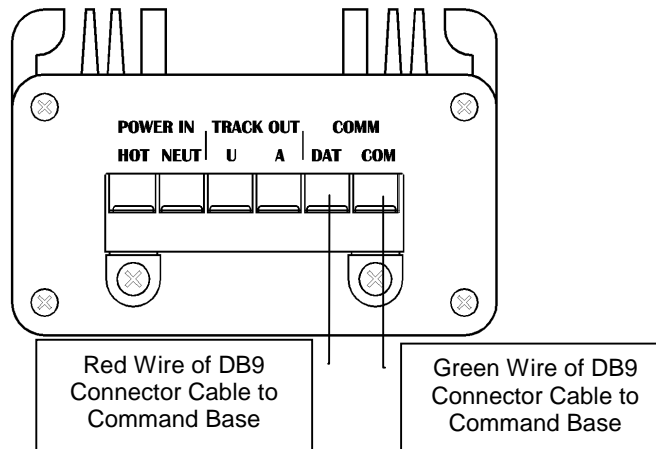

## ***CONNECTING THE TPC TO THE COMMAND BASE***

---

The ALC3000 controller family requires a cable to be connected from the Command Base to the ALC3000 controller family. Using a simple two-wire cable does this. The cable should be made of #22 gauge stranded wire containing a RED and GREEN wire. This cable may be purchased ready-made from IC Controls as #ICC3001-6' or -20'. You may choose to build your own cable. The details of how to do this are as follows. The connector required to hook to the command base is called a Male DB-9 (Radio Shack Part #276-1537). Connect the RED (DAT) wire to pin 2 of the DB9 connector. Connect the GREEN (COM) wire to pin 5 of the DB9.

Connecting the ALC3000 controller family to the Command base.

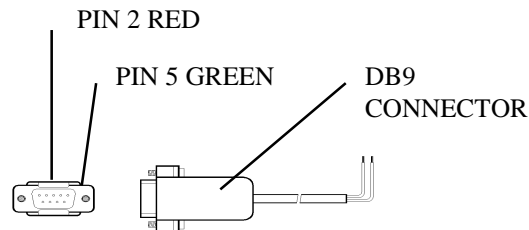

- Start by connecting the DB9 end of the cable to the Command Base marked Computer
- Connect the RED wire from pin 2 of DB9 connector to the DAT terminal of the COMM connector located on the back of the TPC3000
- Connect the GREEN wire from pin 5 of the DB9 connector to the COM of the COMM connector located on the back of the TPC3000. Additional ALC3000 family members can be added by simply daisy chaining the RED (DAT) and GREEN (COM) wires from this TPC3000 to the next controller
- When making your own cable the RED (DAT) wire should be connected to the DB9 pin 2. The GREEN (COM) wire should be connected to the DB9 pin 5.

# **GENERAL OPERATION**

---

## **Run/Program Switch**

The Run/Program switch is located on the front of the TPC3000. The switch has two positions left sets it for RUN operations and right for PROGRAM operations.

When in the PROGRAM position the address of the TPC3000 is set. The address is not saved until you press the SET button. It is used to assign the address to the track or loop. Pressing the SET button will save or set the address.

In the RUN position the TPC3000 that you wish to save information to, the mode of operation, either conventional or command is saved along with the current or maximum speed limit. All settings that are SET will be restored the next time the layout is powered up.

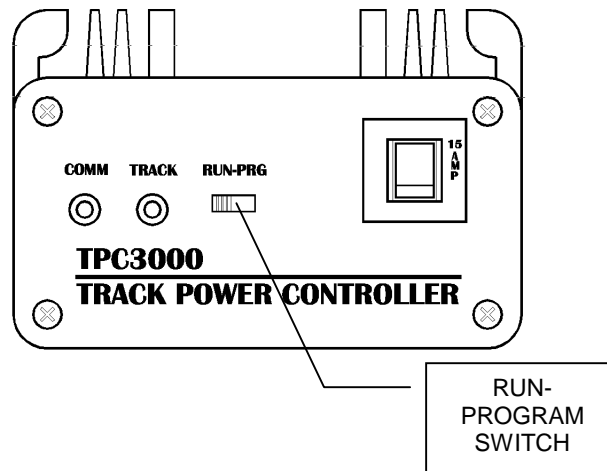

## **Use of LED lights**

The LED lights located on the front of the TPC3000 controller are marked COMM and TRACK. The COMM LED indicates the mode that the TPC3000 is running in. The TRACK indicates the amount of the track power being applied to the track. There are three different types of flashes with the COMM LED, the quick flash, short blink, and long blink to indicate the different functions of the controller.

## Comm LED

Quick Flash This flash is a 10<sup>th</sup> of a second in duration. (It flashes so fast you can hardly see it, like if you were to say one thousand and one, you would only be able to say one thou). A quick flash indicates the TPC3000 is receiving information from the command base.

Short Blink A ½ second short blink indicates the TPC3000 has received a command telling it to do something. It indicates normal operation when the track is selected on the hand held.

Long Blink A one (1) second Long Blink indicates the TPC3000 has a **(SET)** command that should be stored into the TPC3000 for later use. An example of the Long Blink is when the Run/Program switch is thrown to the PRG

## TRACK LED

The TRACK LED indicates the amount of the track power being applied to the track. In Command mode this light will blink indicating that it is running in command mode. The LED will Slow blink when Command mode is selected but no power is applied to the track. The LED will Fast blink when the unit is in command mode and full voltage is on the track. In Conventional mode the LED light intensity will vary with the track voltage.

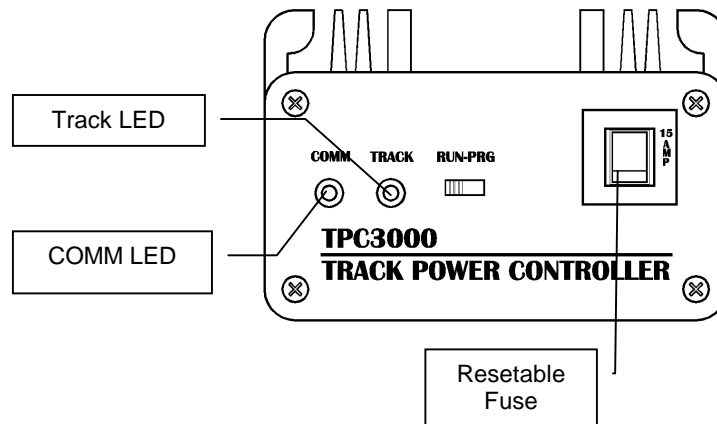

# SETTING THE OPERATION MODES

## General Overview

The TPC3000 has the capability of supplying 300 watts of power to the track. Each TPC3000 will control the voltage to one loop of track, you can hook up to 10 units per layout with 10 loops. Giving you the pleasure of running up to 10 different locomotives. Each can operate in two different modes, conventional and command. In conventional mode you are able to run conventional locomotives without decoders right from a hand held controller such as the CAB-1. It will give you all the features of having a decoder without the need to converting your engine. In command mode full track power is applied to the track allowing you to operate command-controlled locomotives.

Now you are able to run all locomotives on one layout with multiple loops of track, even MTH engines with Protosound. Up to as many as 10 locomotives as mentioned before, each loop gets its own address (0-9). In multiple loop layouts crossing from loop to the next is no problem as long as each TPC3000 is set to approximately the same voltage.

## Command Mode

Command mode is used only when your locomotives have decoders and require full voltage to the track at all times.

Use the **(TR)** (Train/Track) followed by the different address number **(0-9)** to select the TPC3000 module. To set the TPC3000 to command mode first select the controller by pressing **(TR)**, then it's number **(0-9)** followed by the **(L)** button on the bottom of the remote. The TRACK light will flash slowly when the TPC3000 is in command mode.

To save this mode for the next time the power is turned on, simply follow this sequence by pressing the **(SET)** button.

### **Power On Command Mode**

Turning the track power on, begin by pressing the **(TR)** button located at the top of the CAB-1 hand held. Next enter the track number you wish to power up **(0-9)**. To power up the track press the **(BOOST)** key and full voltage is applied to the track. This example turns the power on to track block #3

- **(TR)** Select power block followed by **(#3)** for track number 3
- Press **(BOOST)** full power is on, the track LED will blink quickly

### **Power Off in Command Mode**

Select the **(TR)** on the remote followed by the track number you wish to turn off, either 0-9. Press the **(AUX1)** button followed by the track number and the power should shut off. This example turns power off to track 3.

- Press **(TR)** followed by **(#3)** and select power block **(#3)**
- **(AUX1)** then **(#0)**, The track LED will slowly blink

### **LED Function in Command Mode**

There are two different blinking functions in Command mode. This was designed to tell you if the TPC3000 is supplying voltage to the track or not. The TRACK LED will quickly blink which tells you that the TPC3000 is supplying power to the track or it will slowly blink telling you that no voltage is being applied.

### ***Saving the setting for the next time of operation***

Select the **(TR)** on the remote followed by the track number you wish to set (0-9). Press the **(L)** button for command mode then followed by the **(SET)** button. This example sets the TPC3000 to block 3 to Command mode. The Run/Prg switch must be on Run

- Press **(TR)** and select power block **(#3)**
- Press **(L)**for command mode Press **(SET)** save for the next time



### Conventional Mode

Conventional mode is used when your locomotive does not have a decoder. Now your engine will run like it has a decoder with all the functions. The only requirement is all locomotives on the same loop or block of track must be part of the same train. The TPC3000 allows you to control the locomotives with 2 ½ times greater speed control than a command-controlled locomotive. Giving you finer control and smoother operation. The following keys control the engine

- **(BOOST)** will speed the motor up until released then return to normal speed
  - **(BRAKE)** will slow the motor down until released then return to normal speed
  - **(F) & (R)** Not used at this time
  - **(RED KNOB)** Controls the speed of the locomotive, turned right or clockwise increases the speed, left or counter clockwise decreases the speed of the locomotive
  - **(< > Direction key)** This key controls the direction of the train. It operates just like the ZW direction control by removing the power to the track for as long as it is pressed. When released the track power is restored to its original value
  - **(Whistle/Horn)** Key will activate the whistle/horn function on the engine
  - **(Bell)** Key will activate the bell function on the locomotive
  - **(AUX1)** Key will turn track power off and enable numeric entry
  - **(AUX2)** Key will pulse the track power at current setting to eliminate the Neutral position of the E Units. To continue in the opposite direction, simply reapply power with the red knob by turning it clockwise. Unit with electronic E units may require the application of power within a few seconds or they will revert back to the neutral setting
  - **(F) AND (R )** Keys are not currently used
- The buttons at the bottom of the CAB-1 hand held are used to set the operation styles of each TPC3000
- **(L)** Sets locomotive to Command mode. Full voltage applied to track

- **(M)** Sets the locomotive to Conventional operation and resets to factory setting. TPC3000 track voltage controlled by **(RED KNOB)**
- **(H)** Sets the maximum speed limit in Conventional mode. Adjust maximum speed you wish to allow then press **(H)** to set as maximum.
- **(AUX1) (7)** Pulses track voltage from current setting to 8 volts then back to current setting. This is used with **(9)** key to create programming pulses for QSI/MTH E units.
- **(AUX1) (8)** Sets the track voltage to 8 volts.
- **(AUX1) (9)** Sets the track voltage to full voltage.

All mode settings are held until power is turned off. Then when the power is reapplied the previously saved settings are restored.

To save the **(L)**, **(M)** or **(H)** setting, press set with the **RUN\PRG** switch to **RUN** followed by the **(SET)** key. This will save these settings for the next time you turn power on.

- **(SET)** – when in the **RUN** position sets the maximum speed limit and the command or conventional mode setting

***For example, lets set the TPC to conventional operation loop 3***

- First throw the Run/Program switch to **RUN**
- Now select the TPC3000 press the **(TR)** button then the number **(#3)** for the track loop
- Next select the **(M)** located at the bottom of the hand held
- Finally select the **(SET)** key to save this setting for the next time

### **Setting the TPC3000 Address Numbers**

Setting the address numbers of the TPC3000 is very easy. First decide which track number you would like to use. Remember TPC3000 controllers are addressed as Train/Tracks **(TR)**.

First set the address of the TPC3000:

- Set the **RUN\PRG switch** to PRG (Program) from the side of the TPC3000 that you wish to set
- Select **(TR)** button on the hand held

- Next select **(# 3)** then press **(SET)**

This set the TPC3000 to run track #3.

The TPC3000's LED should, Long Blink for one (1) second, indicating that you have set the motor number.

- Reset the RUN/PRG to run

To test the function: Select **(TR)** Select the **(# 3)** Now operate the **(RED KNOB)** back and forth

The LED should Short Blink (not Quick Flash) if you have set it correctly when you move the **(RED KNOB)** back and forth.

### **Using QSI/MTH features with CAB-1**

Additional features have been added to the TPC3000 making the operation of QSI/MTH E units easier. The first is the power up sequencer. This feature allows QSI/MTH E Units to operate with the TrainMaster system.

### **Powering Up**

To power up track #1 with a QSI/MTH E unit press the following keys

- **(TR) (#1)** select track #1
- **(AUX1) (#9)** performs QSI/MTH power up After engine sounds begin to operate, press
- **(#8)** Do not press the (AUX1) button when switching between **(#9)** an **(#8)**.
- Always press **(#8)** before selecting the direction key

The second is the programming button. This button allows the voltage to toggle between 8 and full voltage. If you accidentally power up the unit without using the above procedure and the engine does not come out of reset, simply turn the power completely off and restart it using this sequence.

### **Programming QSI/MTH**

To use the programming function from the CAB-1. First complete the power sequence listed above. Then perform the following:

- **(AUX1)** Reset engine by completely removing power
- **(#9)** This places full voltage on the track.
- **(#7)** Sends programming pulse to QSI/MTH units.

Repeat the **(#7)** key sequence until the desired feature is selected then press the whistle. Again do not press the (AUX1) Between the selection of **(#9)** and **(#7)**. Consult your MTH engine operating instructions for specific details.

# ***Trouble Shooting Guide***

---

## **Train doesn't run**

- Check to see if the transformer is on,
- Make sure the command base is plugged in
- Check all fuses to see if they are blown
- Check POWER light blinks when the remote is operating
- Make sure the LED is blinking on the command base
- TRACK LED fast blinks in Command mode and long blinks when track power is on
- Make sure the power is turned up enough by rotating the RED KNOB clockwise

## **Train only goes so fast**

- Speed limit could be set, to reset the speed limit to maximum press the **(M)** key, turn the RED KNOB to the desired speed and press **(H)**
- Check input voltage from the transformer

## **Power does not shut off**

- Hit the HALT button, this will immediately turn off the power to the track. To restore power to the track, select the TPC3000 and reapply power.

## **Multiple block layout cannot select different blocks**

- Check to see if the address is set correctly, there can be up to 10 different blocks per layout. Each TPC requires different addresses. Reset the address by throwing the RUN/PRG switch to PRG position, press TR followed by the correct track # then the SET key, Return the RUN/PRG switch to the RUN position

### **Flashing light on TRACK LED in Conventional Mode**

- Running in Command mode, to switch to Conventional mode press the **(M)** key on the bottom of the hand held then press SET

### **Horn/Bell key works in opposite of what is on the remote**

- The A and U wires are crossed, switch the wires

### **Switching from full power or command mode to the track**

- Select TPC3000 by TR followed by track #
- Select **(L)** for Command mode
- Press **BOOST** to turn power on

### **All lights are functioning but engine doesn't run**

- Track voltage may be too low. Turn the RED KNOB clockwise to increase the voltage being applied to the track
- Check wire connection to track

### **TPC3000 COMM light only flashes when selected**

- The TPC3000 address is not set correctly, reset the address by throwing the **RUN/PRG** switch to **PRG** position, press **TR** followed by the correct track # then the **SET** key, Return the **RUN/PRG** switch to the **RUN** position. When set properly COMM LED will blink and not flash when selected.

### **Engine doesn't come out of reset**

- Turn power completely OFF then use QSI/MTH power up sequence in QSI/MTH operating section.

## WIRING EXAMPLES

---

### ***Simple Wiring***

**WARNING!** When wiring the TPC3000 to the transformer and the track you must use at least 16-gauge wire or larger.

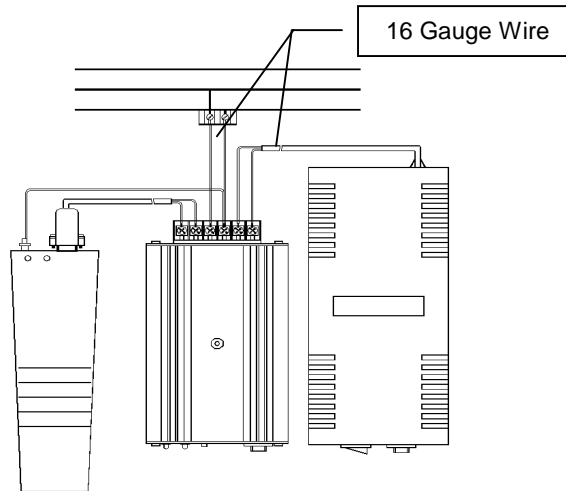

Wiring and operating with the TPC3000 with one track loop as TR number 1 refer to the wiring diagram below.

- Throw the **RUN/PRG Switch** to the **PRG** position on TPC3000 that you wish to set
- Select **(TR)** button on the hand held
- Next select **(# 1)** for **(TR 1)** remember the track will be set to this number
- Then press **(SET)**
- Throw the switch back to the Run position
- Select **(M)** for conventional mode, then press **(SET)**

**To operate: Select (TR) (#1)**

- Turn the **(RED KNOB)** clockwise to increase the speed of the engine to decrease the speed turn the knob counter clockwise
- Press **(DIR)** key to change the direction

## **Connecting two Powerhouses to supply 300 Watts of power to your track!**

**WARNING!** When wiring the TPC3000 to the transformer and the track you must use at least 16-gauge wire.

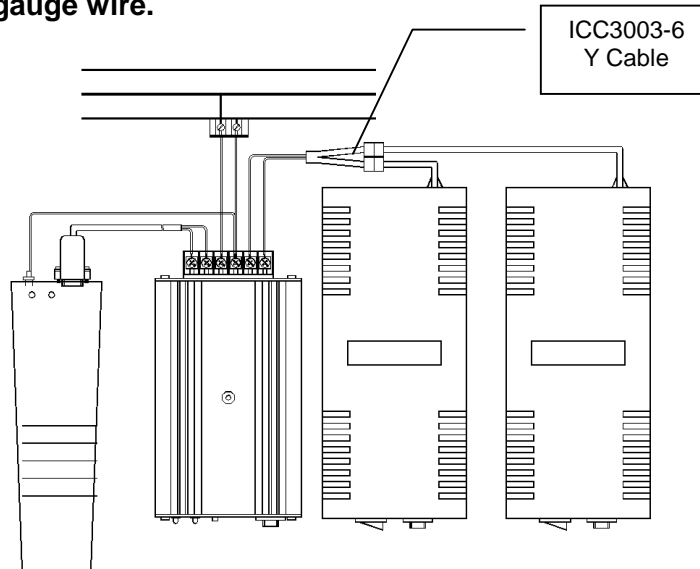

If your current transformer can supply 300 Watts or more simply connect it directly to the power input terminals. The TPC3000 will limit the power to 300Watts at the track. Two Powerhouses can be wired together to supply your track with 270 Watts. This is done by connecting two powerhouses in parallel. This is accomplished by using a Y cable connection. Note the phasing of the two transformers must be the same for both the input and output sides of the transformers. IC Controls has a pre-assembled Y cable available (Part #ICC3003-6 for \$9.95) for this purpose. All other connections will be the same as if you were setting up a single transformer.



## Wiring two or more separate blocks or track

**WARNING!** When wiring the TPC3000 to the transformer and the track you must use at least 16-gauge wire.

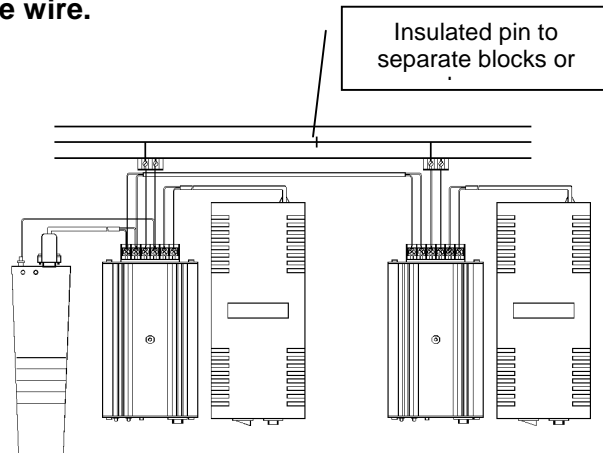

Wiring more than one TPC3000 to a layout is easy. It requires you to insulate the center rail of each loop or block of track. If the track is a continuous loop and you want to make two separate blocks, both ends must be insulated making the loop two separate sections. The above diagram shows the insulating pin location and the connections to the two TPC3000s.

The diagram below shows how to separate two loops. **Note:** All connections from the outer loop to the inner loop must be insulated. This type of isolation is the same as if you were running two separate conventional transformers to operate the same layout.

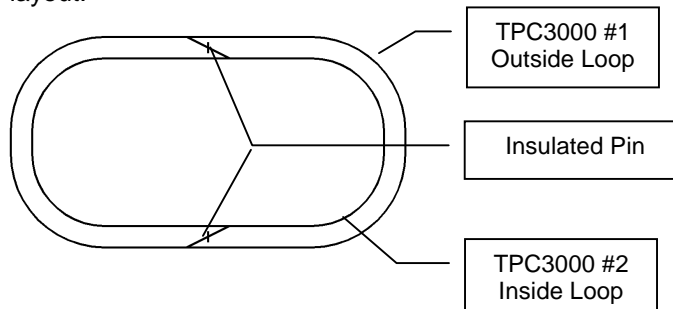

## ***Additional Information and Technical Support***

---

IC Control is continually trying to make its products the best in the market place. Your input on our products is very important to us. It allows us to shape our products to your needs. If you have any comments or questions on any of our products please feel free to contact us either by phone 1.800.200.3277 or 1.734.697.4153 or by mail with the following address.

## ***Warranty Information***

---

IC Controls stands behind their products with a one-year parts and labor warranty. If the product fails to operate because of manufacture defect, IC Controls will repair or replace it at their discretion free of charge for a period of one year from the date of purchase. To return defective product please include the following:

- Defective unit
- Dated sales receipt
- Reason for return
- A check for \$5.00 to cover postage and handling

### ***Send the above information to:***

IC Controls  
P.O. Box 296  
New Boston, MI 48164  
ATT: Returns Dept.

### ***Please allow 2 to 3 weeks for processing.***

*The ALC3000 Controller Series is a registered trademark and has patents pending. All other ALC family names are trademarks.*

*Lionel Trainmaster is a registered trademark of Lionel Inc., CAB-1, Command base, SC-1 are trademarks of Lionel Trains In*



TPC3000

Technical Reference Manual Version 1.2

Acc\msoffice\winword\iccontrols\tpc3000-1.2.dot